

## Design and set up of a pulverized panela machine

J G Maradey - Lázaro<sup>1\*</sup>, A D Rincón-Quintero<sup>2,3</sup>, C L Sandoval- Rodríguez<sup>2,3</sup>, O Lengerke-Pérez<sup>3</sup>, J F Castellanos- Hernández<sup>1</sup>

<sup>1\*</sup> Mechatronic Engineering Program, Universidad Autónoma de Bucaramanga, Avenida 42#48-11 Cabecera del Llano, Bucaramanga, 680003, Colombia.

<sup>2</sup> University of the Basque Country, Ingeniero Torres Quevedo Plaza, 1, 48013 Vizcaya Spain.

<sup>3</sup> Faculty of Natural Sciences and Engineering, Unidades Tecnológicas de Santander, Student street 9-82, Bucaramanga, 680005, Colombia

---

### ABSTRACT

The panela is a food well known in the world for its benefits to humans since provides energy necessary and essential nutrients for the development of the body's metabolic processes. This is obtained from sugar cane, and a substance-free ingredient that can affect health. While, in culinary and gastronomic arts sector is used as a sweetener. The process of obtaining the panela is developed by successive and prolonged boiling, which causes moisture loss and then concentrates and forms a tiny mass that when cooled solidifies into blocks. The research work carried out focuses on the static and dynamic analysis of the designed parts that allow various processes (whipped, sifted, and dried) for large-scale panela production, analyzes the behavior under different loads (mechanical stress, displacement, and thermal study) based on Finite Element Analysis (FEA) using SolidWorks and Comsol Multiphysics software. Clearly, is important to mention that an appropriate size for the mesh was considered along with Von Mises criteria to be compared with the elastic limit of the selected material for the definition of the final prototype which was designed following the Pahl and Beitz design methodology respectively. A modal analysis of the panela pulverized machine was performed to verify natural process frequencies and vibration modes. Also, a friendly HMI interface for the user was implemented considering the characterization of the users (workers, farmers) and the nature of the process (artisanal). The start-up of the panela pulverizing machine showed a dependence on the consistency and origin of the molasses, depending on this the capacity and size of the pulverized panela.

---

**Keywords:** panela pulverized, process design, food, agricultural products.

### *Corresponding Author:*

Jessica Gissella Maradey Lázaro  
Mechatronic Engineering Program  
Universidad Autónoma de Bucaramanga,  
Avenida 42#48-11 Cabecera del Llano, Bucaramanga, 680003, Colombia  
E-mail: jmaradey@unab.edu.co

---

### 1. Introduction

According to the information from the Food and Agriculture Organization of the United Nations (FAO), 25 countries in the world produce panela, of which Colombia is the second producer after India, with a profit of 1,674,733 tons / year [1]. The process of obtaining the panela is developed by successive and prolonged boiling, which causes moisture loss and then concentrates and forms a tiny mass that when cooled solidifies into blocks. Sugarcane cultivation and panela production takes place in warm areas of South American countries, such as Colombia, Mexico, Ecuador, Bolivia, and Peru, however, it is also produced in India (largest producer) and Pakistan. It is important to clarify that to obtain the panela, a process is carried out from the sugar cane, using a machine known as a panela sprayer with three additional stages, smoothing, spraying, and sifting. After, process such as whipped, sifted, and dried was carried out with the purpose of obtaining pulverized panela.

The panela production industry constitutes the second most developed agro-industrial activity in Colombia, contributing 3.02% of the gross domestic product (GDP). The area of La Hoya del Río Suarez presents the highest degree of technification in crops, with an average yield of 120 tons of cane per hectare and in some cases up to 200 tons / h.

Also, the panela agroindustry offers competitive advantages compared to other sectors, due to legal protections, tax exemptions, a high degree of recognition of the product in the national population, because thanks to being the first panela consumer country in the world, practically all of production is consumed internally in the country. However, job creation is the most important impact positive of the industry since it favors the income of economic resources and the increase of farmer's quality of life [2].

Panela has been considered as a complete food, since has nutritional components such as sugars (sucrose, glucose, and fructose), vitamins (A, B, C, D and E) and minerals (potassium, calcium, phosphorus, magnesium, iron, copper, zinc and manganese, among others) [1], [2].

Several companies have ventured into the development of new products, flavors and presentations, examples of these are pulverized panela, the aromatic panela in sachet presentation and the new flavors of the cubes such as fresh fruits, orange, cinnamon, passion fruit, lemon, citron, and peppermint. Natural pulverized panela and flavors such as lemon, cinnamon, passion fruit, provide a portfolio of indigenous and traditional products, which through different automation processes provide the possibility of entering new markets at the level of synthetic sweeteners and sweeteners.

However, the processes for obtaining pulverized panela are carried out in an artisanal, empirical way and rooted in the ambiguous customs of the regions where it is produced, which considering the current demand for sugar substitute products makes the sector not very competitive and maintains a long, poor, and expensive process. Then, the use of appropriate equipment for spraying panela in small and large mills is essential, to streamline activities, homogenize the product and reduce losses of time (efficiency) and raw material. The incorporation of technology allows the main process variables to be monitored and controlled, managing to improve efficiency and performance in each of the stages required to produce panela.

The main objective of this research is the design and construction of a machine that allows the automation of the whipping, pulverizing and sifting processes to produce panela in sectors where this activity is still carried out in an artisanal way. Particularly, on average, the Santander region has a production of 660 tons / day of cane in full stage, however, only 20% (40.8 tons / day) of this cane is dedicated to the panela industry. The automation process presented in this document aims to achieve an improvement in performance by increasing the production of panela by 60%, thus reducing the performance times that are now managed.

### 1.1. Highlights of panela

Panela in the national market and, even more so, in the international market, ventures as a product of high added value, where its nutritional benefits stand out. However, its main disadvantage is related to the difficulty of handling. For this reason, the massive consumption of panela will spread when the presentation facilitates its use (pulverized). According to this, the panela industry requires new equipment that allows to obtain more efficient in the production process, reducing production costs, improving, standardizing the quality of the product, especially its presentation and product safety [3]. Other important factor is facilitating the manipulation of the farmer allowing to balance the workloads and allow the access to new markets improvement production conditions [3], [4]. A strategy to achieve this is determine the activities of value in the supply and production chain with market study even perspectives and trends [3].

Then, is necessary to recognize other influence factors in panela production process such as climate change, institutional presence, financial resources, asociativity, technical assistance [2], [3].

Furthermore, the consumption of panela fulfills two main functions: the first is related a food with special nutritional characteristics. The second function is that it acts as a sweetening ingredient in other foods. In fact, household panela consumption is being displaced by other direct substitute products such as sugar and synthetic sweeteners, and indirect ones such as soft drinks and artificial soft drinks with low nutritional value. Panela has gradually lost its share of the food basket worldwide, especially that of urban middle- and upper-income households. Some previous studies have shown that cost and "sweetness" are factors that make consumers prefer the consumption of sugar over panela as a sweetener [5], [6]. While in Europe, for example, the consumers profile require organically produced food, quality, and know the origin [7], [8].

Figure 1 shows the consumption of traditional panela (block, round, and pill) and pulverized panela is observed, where it is determined that traditional panela until 2014 had significant consumption, almost 70% more than the

consumption of the pulverized panela; in the same way, the continuous growth of consumption that pulverized panela has had in the period 2014 to 2016 is highlighted, which has been approximately 68%, however it cannot be affirmed the same of the traditional panela since it has had a decrease of approximately 52% [5]. This is due to the change in culture regarding the way of purchasing and consuming the product.

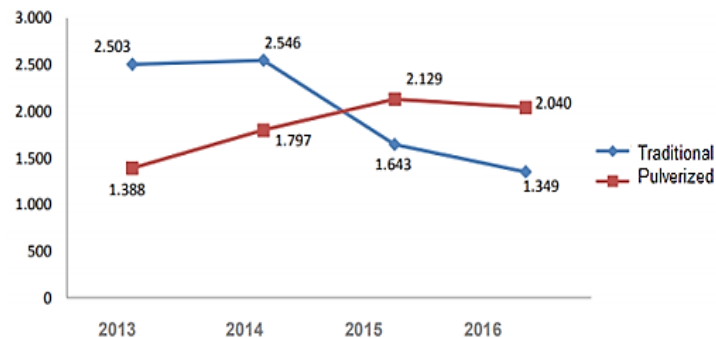

Figure 1. Consumption of traditional and pulverized panela in Colombia in recent years [9]

As for the panela production process, in Figure 2 is shown the processes and each stage such as: cutting, tightening, extraction, pre-cleaning, clarification, evaporation and concentration, whipping and tapping, pouring the whipping, mold and packing.

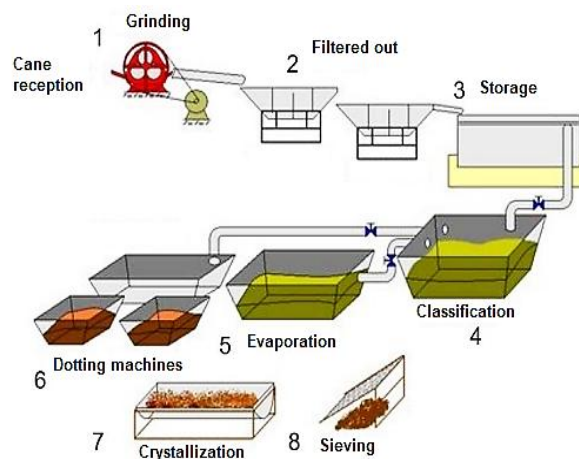

Figure 2. Panela production flowchart [7]

One of the most important process in pulverized panela production is the beating. In Figure 3 can be seen this process. This is an intensive shaking action and intermittent honeys, which takes place from simultaneously with cooling in a period time between 10 and 15 minutes. Currently, the temperature decrease continues and, with agitation permanent manual, define texture, delete adherence, and increases the porosity of the honeys. The beating is done manually and involves extreme conditions for the operators, repetitive movements, and displacement of loads greater and exposure at high temperatures [2],[10]. Therefore, between the objectives of the pulverized panela machine is to automate this process.

To sum up, the most significant environmental impacts of the process are evidenced during the evaporation stage and concentration of juices, mainly due to the use of traditional burners. Figure 4 illustrates this process. These burners are installed without considering the requirements particular of each sugar mill, which causes losses energy emitted in the form of water vapor released into the environment without any kind of control, emissions that cause alterations in the microclimate of the place. Additionally, these traditional burners use inefficient fossil fuels that cause incomplete combustions, which generate gases toxic that contribute to the greenhouse effect [2], [11]. Also, the implementation of techniques or strategies for efficient waste management could be suggested [12], [13].

Figure 5 shows the sieving process which is crucial to pulverized panela.



Figure 3. Beating and tapped process



Figure 4. Evaporation process



Figure 5. Sieving process

## 2. Methodology of design

The Pahl and Beitz design methodology is presented, which uses systems theory to support the research proposal through functions and sub-functions that combine physical effects with design characteristics and parameters, so that this is how the solution principle emerges. The process is shown in Figure 6.

Then, there is the need to be satisfied, in this case that of facilitating and increasing the process of obtaining pulverized panela by automating its performance stages. The functions corresponding to the previous work are specified, such as research and review of the literature on panela spraying machines and the implementation of need analysis diagrams. Then the system specifications are made, which correspond to mixing and cooking the sugar cane, dosing it in powder and monitoring the dosage through an HMI interface. After, we proceed to define the subsystems and design components of the machine, where the interface is implemented, the resistance that the structure must have is foreseen and the components such as sensors, actuators, software, and others are considered. Based on this, a prototype of the end is reached.

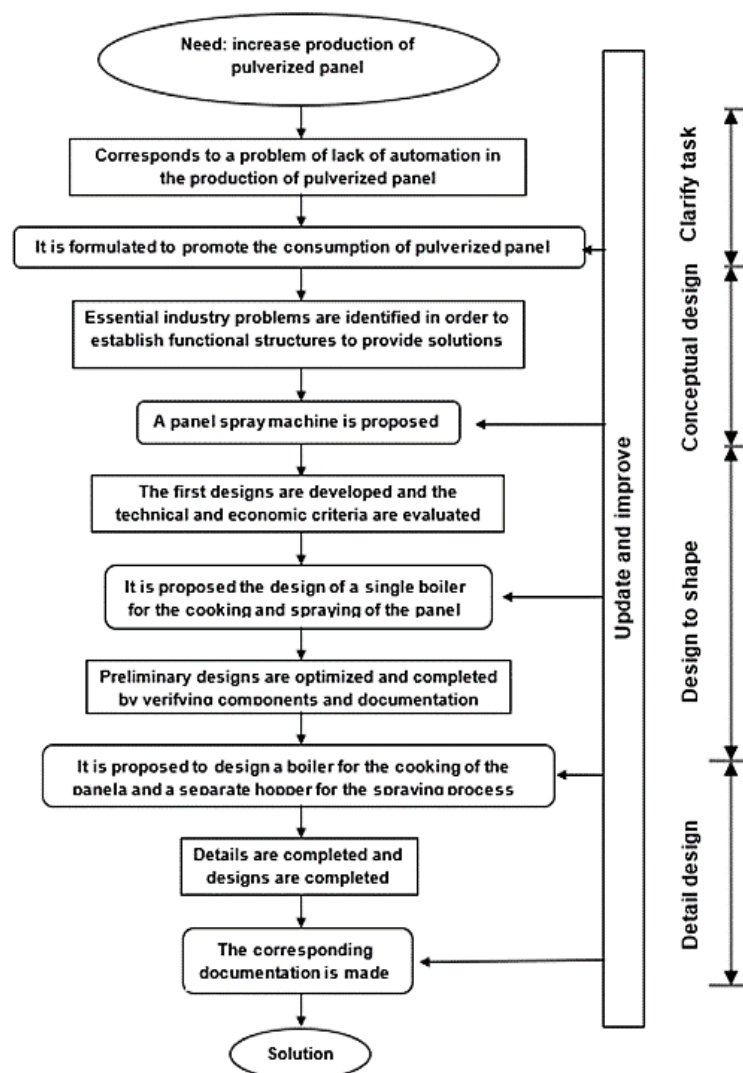

Figure 6. Pahl and Beitz design methodology applied to panela pulverized machine

### 2.1. Design of Panela Pulverized Machine

This section develops the structural design of the panela pulverized machine. The material that was raised for the construction of the machine was stainless steel, this because is a completely hygienic material since allows cleaning frequently without exposure to corrosion. Commonly, this material is used to build automation processes where the food or health part must do.

Firstly, the main dimensions of the tank and the pallets are formulated by calculating the production proportions of the food, respectively.

The calculation starts from the density and mass contained in the main container, so:

$$V_m = \frac{m_m}{\rho_m} = \frac{2[Kg]}{540\left[\frac{Kg}{m^3}\right]} \quad (1)$$

$$V_m = 0,003794[m^3]; 3,794[Lt]$$

Where  $V_m$  is the volume occupied by the material to be whipped,  $m_m$  is the mass material and  $\rho_m$  is its density. After, we proceed to calculate the dimensions starting from the equation of the volume of a cylinder

$$V = \frac{\pi}{4} D^2 H \quad (2)$$

Taking this,

$$D = 2H \quad (3)$$

Solving the equations system, we get:

$$D = 20[cm]; H = 10[cm]$$

Then, to calculate the power of the motor is necessary to determine the type of fluid that is obtained from the panela in its cooking, which obeys a Newtonian behavior. Based on existing information on the viscous properties of the fluid, the corresponding calculations are carried out.

Reynolds number is calculated using the following equation:

$$Re = \frac{N * d^2 * \rho}{\mu} \quad (4)$$

Replacing,

$$Re = 43573$$

Then, the power is obtained through the next expression:

$$P = N_p * N^3 * d^5 * \rho \quad (5)$$

Obtaining,

$$P = 25,6[W]$$

Indeed, is assumed that the lower blades coupled to the shaft consume the same amount of power as the upper blades, thus applying a safety factor of 1.5 due to inefficiencies in the motor and the texture that the mix is acquiring when whipping.

$$P = 76,8[W]$$

Based on these obtained results, a motor of 100 [W] to 100[rpm] is chosen.

Thus, regarding the calculation of the main axis of the machine, the diameter of the part is calculated using a free-body diagram. The efforts are concentrated in 2 specific places, where the whisk blades are located. It is assumed that the power consumed by each group of blades is the same, since the pulverized panela has very similar properties at each stage of the process. The following correlations are used to calculate the power:

$$P = \tau * \omega \quad (6)$$

Where  $\tau$  is the torque and  $\omega$  is the angular velocity. Clearing the torque and replacing the data we obtain that:

$$\tau_m = 9,58[Nm]$$

Value corresponding to the torque that the motor must have.

Now, we proceed to calculate the diameter of the shaft with the following equations,

$$d = \left\{ \frac{32N_f}{\pi} \left[ \left( K_f \frac{M_a}{S_f} \right)^2 + \frac{3}{4} \left( \frac{\tau_m}{S_y} \right)^2 \right]^{\frac{1}{2}} \right\}^{\frac{1}{3}} \quad (7)$$

In this case, there are no applied transverse forces causing flexing, thus,  $M_a=0$ , and the equation reduces to:

$$d = \left\{ \frac{16\sqrt{3}N_f}{\pi} \left( \frac{\tau_m}{S_y} \right) \right\}^{\frac{1}{3}} \quad (8)$$

Where  $N_f$  is the safety factor,  $\tau_m$  corresponds to the mean torque and  $S_y$  is the creep resistance of the material. AISI 304 steel and a factor of safety of 2.5 were selected.

After, in Figure 7 a free body diagram of the shaft, where all the forces present on the blades and coupling act is shown. Therefore, is possible to have a clearer focus on the role of this part in the panela spraying machine, since is one of the most important elements of the system.

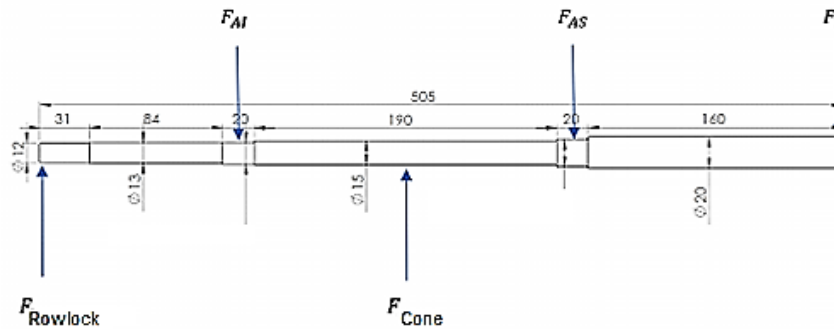

Figure 7. Free body diagram of the shaft

Where  $F_{AI}$  corresponds to the force of the lower blade,  $F_{AS}$  to the upper blade y  $F_2$  to the coupling of the motor. The force made by the blades and that exerted by the coupling correspond respectively to

$$F_{blade} = m_{blade} * g \quad (9)$$

$$F_{coupling} = m_{coupling} * g \quad (10)$$

Where  $m_{as}$  corresponds to the mass of the Blades and  $m_{ac}$  to the mass of the coupling. Obtaining in this way the static analysis in the XY and XZ planes, respectively.

$$F_{rowlock y} + F_{cone} = F_{AI} + F_{AS} + F_{coupling} \quad (11)$$

$$F_{rowlock z} + F_{cone} = 2F_{blade} \quad (12)$$

There is a flow resistance of steel 1020 corresponding to

$$S_y = 3,70 \times 10^6 [Mpa]$$

$$S_u = 440 \times 10^6 \text{ [Mpa]}$$

$$N = 2,5$$

Finally, the diameter of the shaft is found using the following equation

$$d = \left\{ \left[ \left( \frac{32N}{\pi} \right) \left( K_f \frac{M}{S_n} \right)^2 + \frac{3}{4} \left( \frac{\tau_{max}}{S_u} \right)^2 \right]^{\frac{1}{2}} \right\}^{\frac{1}{3}} \quad (13)$$

Obtaining a minimum measurement of 12.6 [mm]. Finally, a commercial value of 15 [mm] is selected for the axis.

## 2.2 Finite Element Analysis (FEA) for Panela Pulverized Machine

Finite Element Analysis (FEA) provides a close prediction of the behavior of a body in real environments, even in the presence of disturbances of field, and forces, among others. Moreover, FEA give an approximate solution of partial differential equations that describe physical problems related to states (e.g. steady and transient) [14]. This approach consist in: pre-processing, solution and post-processing. The major advantage of FEA is accuracy level, facilitates the critical variables analysis and increase the productivity and computational efficiency [14]. Similarly, in this work, FEA is used to check the mechanical resistance [15].

For the mechanical system of the pulverized panela machine, the stresses, displacements, and safety factors were calculated using SolidWorks software based on the forces applied to each of the components of the prototype shown in Figure 8. Modal and thermal analysis was performed on some parts.

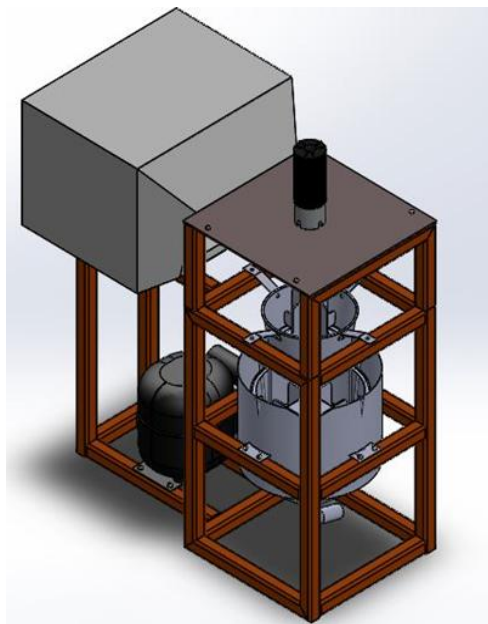

Figure 8. 3-D solid panela pulverized machine

The first piece corresponds to the main hopper. The stresses on this tank are due to the Von Mises tension with a minimum of  $0 \text{ N / m}^2$  and a maximum of  $1.5e7 \text{ N / m}^2$ . The second effort corresponds to a resulting displacement  $U_{res}$  with a minimum of  $1e-6 \text{ m}$  and a maximum of  $1.2e-5 \text{ m}$ .

Figure 9 shows the stresses to which the tank is subjected, due to the force exerted by the mixture on it. The elastic limit  $S_y$  that supports stainless steel is 170 MPa, and the maximum value of tension exerted on the tank is 15 MPa. In other words, the maximum value of tension to which the tank will be subjected does not exceed

the elastic limit, therefore there will be no complications in the correct operation of the tank in terms of tension forces.

Figure 10 indicates the displacements on the hopper, the area in which there is the greatest displacement and the area in which there is a minimum displacement. The maximum displacement value indicated in the red zone of the tank is  $1.2 \times 10^{-5}$  m, this being a value that will not influence the correct operation of the tank. Therefore, the design of the hopper is correct there will be no problems regarding the displacement forces.

The safety factor shown in Figure 11 shows if the design will withstand the forces to which it will be subjected, in case of failure the safety factor would be less than 1, as a precaution, we will use a safety factor greater than 2, and as can be seen in the Figure, the minimum value of the tank safety factor is set to 12. Thus, the design of the hopper is correct and can withstand the forces caused by the mixture, making its construction adequate.

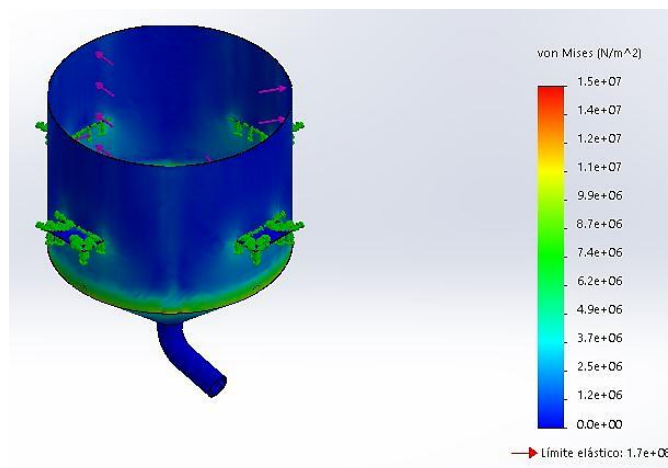

Figure 9. Von Mises Stress analysis on the hopper

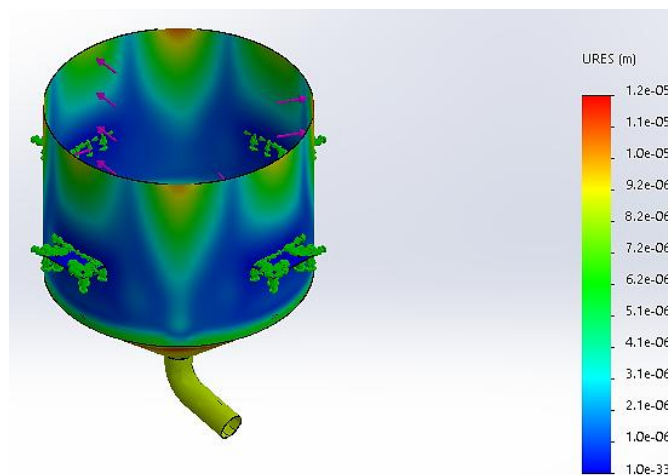

Figure 10. Displacement analysis on the hopper

Next, we proceed to perform the mechanical analysis of the structure that supports the machine components shown in Figure 12. The efforts on the support are due to the Von Mises tension with a minimum of  $0 \text{ N/m}^2$  and a maximum of  $3.9 \times 10^6 \text{ N/m}^2$ . The second effort corresponds to a resulting displacement with a minimum of  $1 \times 10^{-6}$  m and a maximum of  $2.1 \times 10^{-4}$  m.

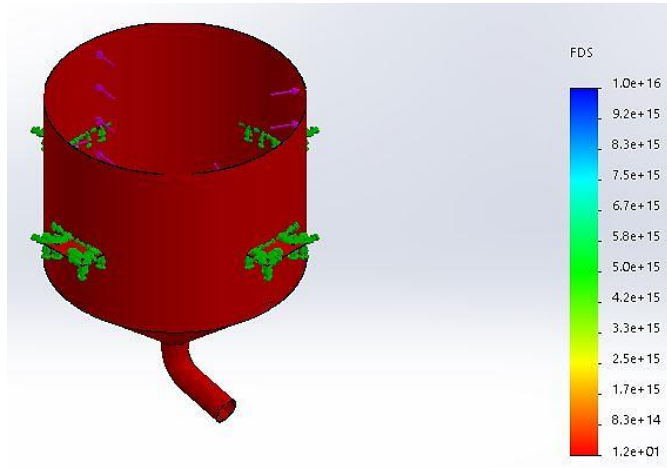

Figure 11. Safety Factor on the hopper

Figure 12 shows the effect of the forces that cause stresses due to the resistance of the pieces of the panela pulverized machine. Specially, the maximum value of stress that this structure supports is 3.9 MPa and the Maximum Elastic Limit that supports stainless steel is 170 MPa.

Therefore, the stress forces produced in the structure do not exceed the elastic limit of the material, and its design and construction are suitable for its correct operation.

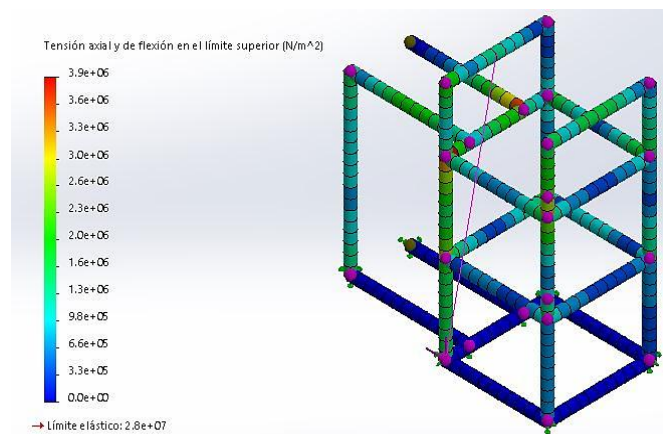

Figure 12. Combined stress on structure machine

As can be seen in the study of the graph, the maximum displacement value that occurs is  $2.1 \times 10^{-4}$  m, this being an admissible value in terms of the displacement allowed in the structure, since the displacement is not very significant in the structure and can function correctly without affecting any process.

The safety factor shown in Figure 14 indicates if the design withstands the forces to which it will be subjected to, in case of failure the safety factor would be less than 1, as a precaution, we will use a safety factor greater than 2.5, and as we can see in the graph the minimum value of the safety factor of the structure is established at 7.

To sum up, the design of the structure is stable and can withstand the forces caused by the parts of the prototype, which makes it suitable for construction.

As the last piece, there is the shaft that runs through the entire panela cooking and pulverizing system, and its respective analysis is carried out, which is also shown in Figure 15.

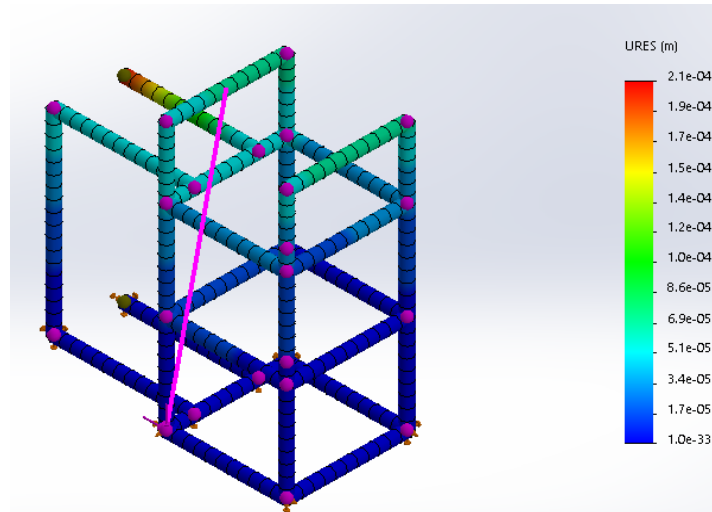

Figure 13. Displacement analysis of structure machine

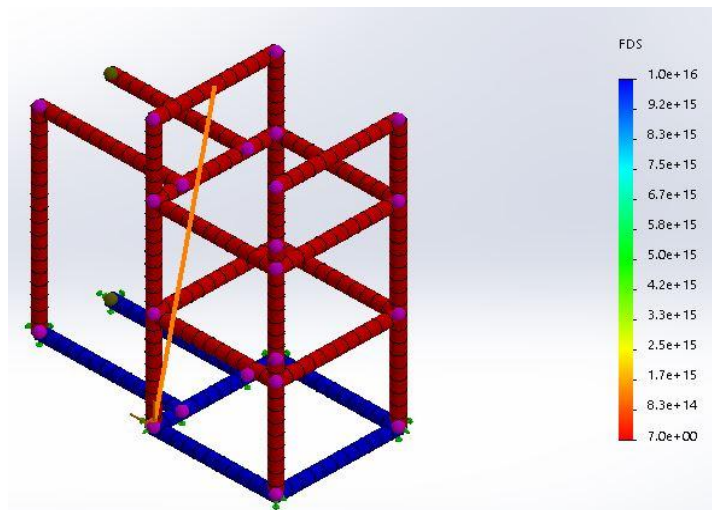

Figure 14. Safety factor of structure machine

Figure 15 shows the effect of the forces that cause stresses due to the blades of the system. In the study carried out, the maximum value of stress that the structure supports are 59 MPa and the maximum elastic limit that supports stainless steel is 172.3 MPa. Therefore, the stress forces produced on the shaft do not exceed the elastic limit of the material, and the design and construction of this part are suitable for its correct operation.

Figure 16 shows the displacements caused in the shaft. As can be seen in the study of the graph, the maximum displacement value that occurs is  $1.9 \times 10^{-4}$  m, this being an admissible value in terms of the displacement allowed in the shaft of the system, since the change that occurs in this part is not significant and can have a correct operation without putting in danger the panela spraying machine.

The safety factor shown in Figure 17 indicates if the design withstands the forces to which it will be subjected, in case of failure the safety factor would be less than 1, as a precaution, we will use a safety factor greater than 2.5, and as we can see in the graph, the minimum value of the safety factor of the base structure is set to 11. As a result, the shaft design is stable and can withstand the forces caused by the blades of the entire system, which makes this piece suitable for construction.

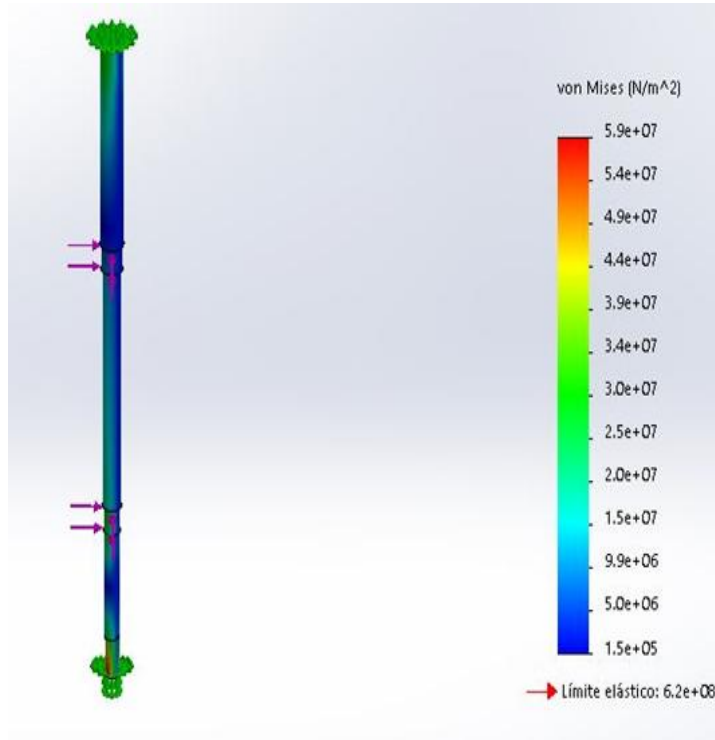

Figure 15. Von Mises stress on the shaft

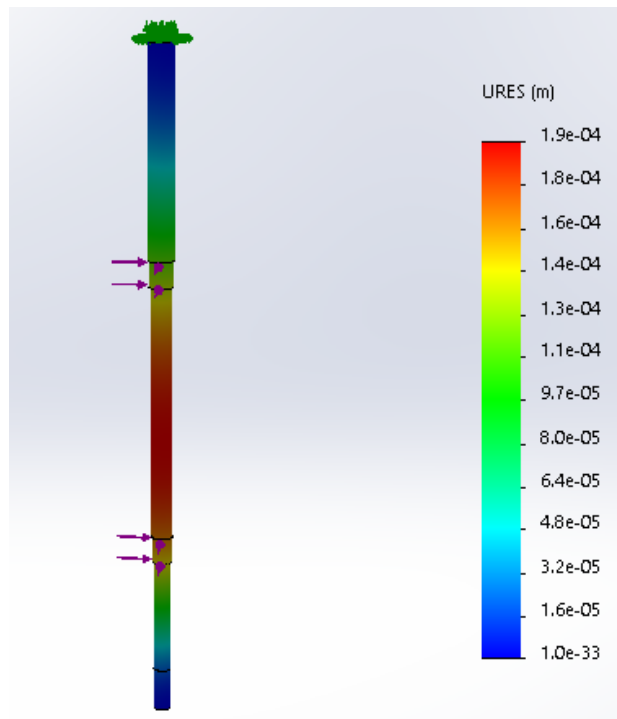

Figure 16. Displacement on the shaft

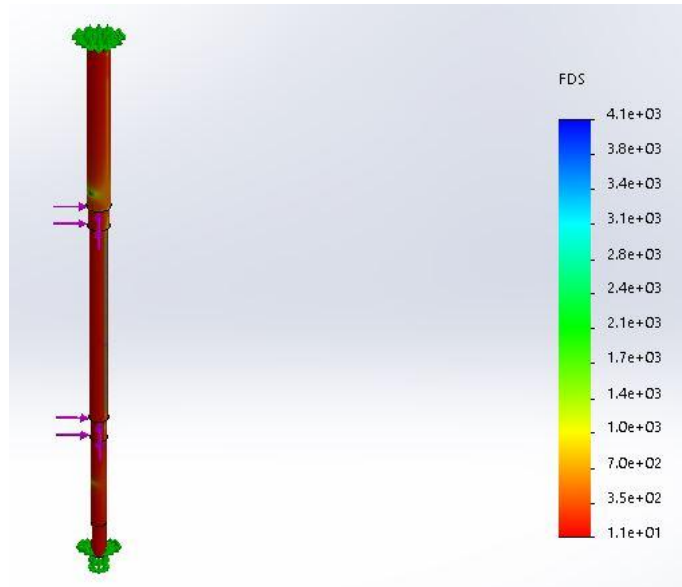

Figure 17. Safety factor on the shaft

Subsequently, a modal or vibration analysis is carried out on the shaft of the system to determine if the vibrations generated by the engine may affect the prototype in the future and cause deformations in the piece. According to the selected motor, the following equation is obtained:

$$Frequency = \frac{rpm}{60[seg]} \quad (14)$$

As a much higher vibration than that calculated in the system is obtained in the simulation, the shaft does not run any risk of deforming due to the vibrations that the motor of the panela spraying machine may cause. Figure 18 shows the maximum amplitude on the shaft.

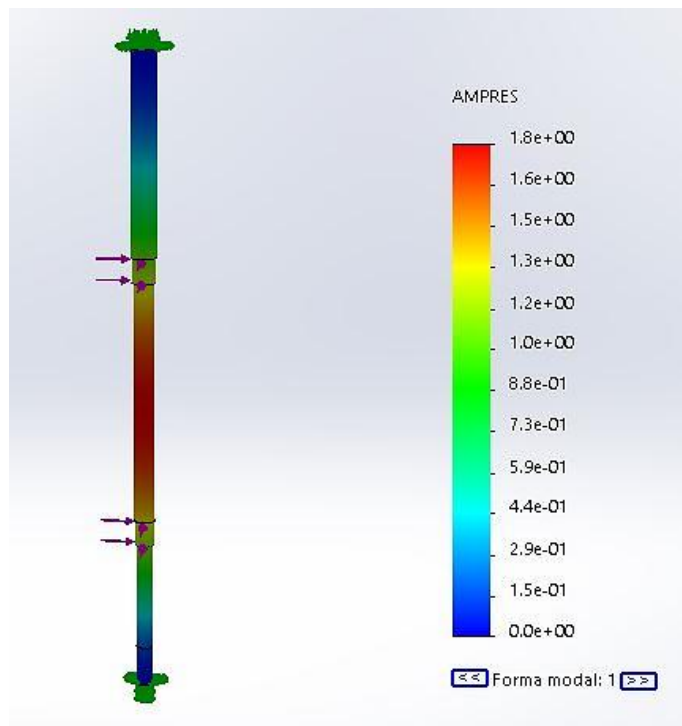

Figure 18. Maximum amplitude caused by vibrations on the shaft

Consequently, temperature analyzes were carried out on the hopper of the system, corresponding to the surface and isosurface temperature, to establish to what extent, the material of this element would withstand the temperature of the panela mixture in cooking. For this it was established that the coefficient of surface expansion

For AISI 304 stainless steel is given by the following value:

$$\sigma = 1,2 \times 10^{-5} [^{\circ}\text{C}^{-1}]$$

and the area of the container is given by

$$S_o = \frac{\pi}{4} * D^4 \tag{16}$$

Thus obtaining that at an average temperature of 25 [° C] the thermal expansion produced in the container is 0.13 [mm], which is not significant to alter the operation of the equipment.

As can be seen in Figures 19 and 20, the temperature reached in both cases by the hopper does not exceed 320 K, so it does not represent a threat to the system.

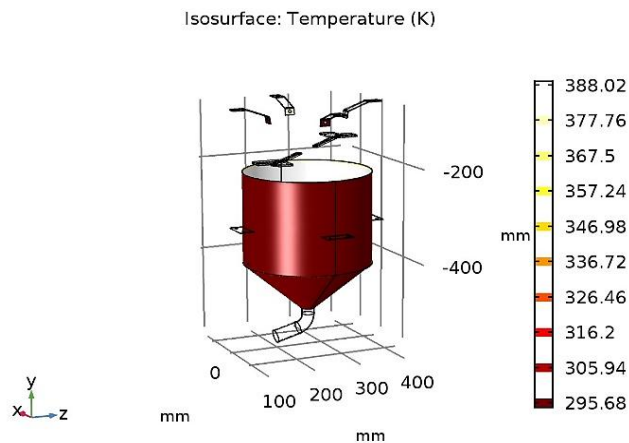

Figure 19. Temperature analysis on the isosurface of the hopper

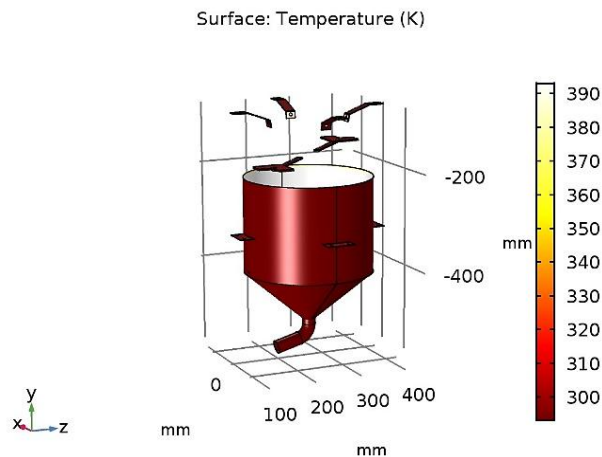

Figure 20. Temperature analysis on the hopper surface

### 2.3 HMI Interface Implementation

The implemented interface shown in Figure 21, was made under the LABVIEW software where two modes of operation are proposed, manual and automatic, in which the user can make changes to the times of the different stages depending on the geographical location in which they want to start the machine, since the height above sea level influences the operation of the pulverized panela machine.

In manual operation, the speed of the motor can be varied in case production requires it and its respective reading can be shown in real time. In this mode of operation, you can define the times in each of the processes respectively, this function in case for climatic reasons and / or height in which the system is located requires; when the panela juice is more optimal, it will be possible to reduce the times and have a more efficient production, also visually you can have information in real time and in what stage or process it is.

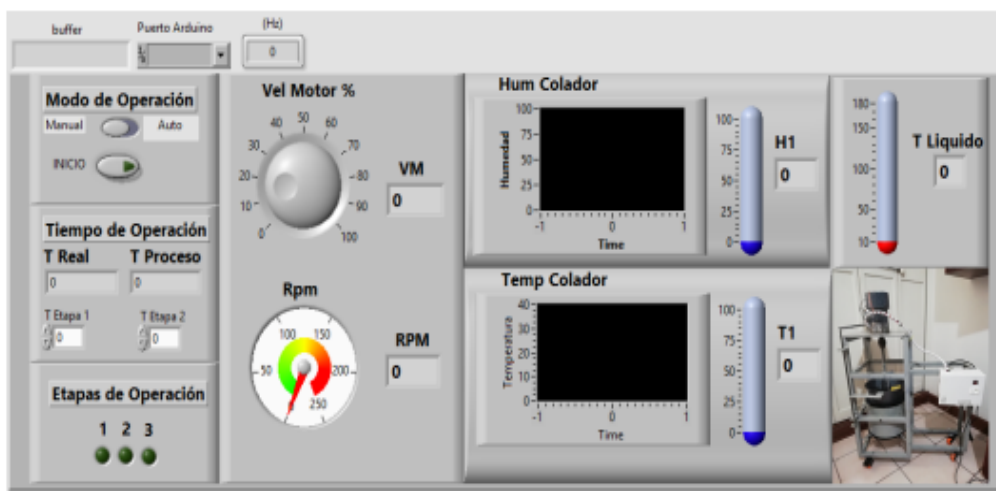

Figure 21. System HMI interface design.

The most relevant features of the HMI interface include tools to simplify the operation of the pulverized panela machine, since templates and add-on instructions (AOIs) allow a quick start and reduce the time of commissioning and Problem resolution.

There are also high graphs that allow the status of the variables to be visualized in real time to be able to proceed with the manipulation and decision-making on the system. The machine provides feedback to the operator the variables that the product presents in the whipping stage graphically with respect to time and magnitude.

Some tests had to be carried out previously such as:

- *Determination of grain size:* The calculation of the grain size was carried out by the granulometry or sieving method, which is any manual or mechanical procedure by means of which the constituent particles of the aggregate can be separated according to sizes, in such a way that the amounts by weight of each size contributing the total weight. Meshes of different openings are used to separate by sizes, which provide the maximum size of the particles. A total of 5 tests were carried out with different degrees of humidity; recording in each one the amount retained by each mesh (sieve). Thus, it was determined that, at minimum moisture values, the amount retained in the content of the 1mm gauge mesh is greater and vice versa. The predominant range of particle size is between less than or equal to 1000 [ $\mu\text{m}$ ] to particles greater than 600 [ $\mu\text{m}$ ]; i.e 0.6mm - 1mm. In conclusion the grain size is between 0.99mm and 0.001mm which is in accordance with literature [16],[17].
- *Determination of Humidity:* Panela is a hygroscopic product, that is, when exposed to the environment it can absorb or lose moisture, depending on the climatic conditions of the environment. To determine the humidity, the universal stove method was used, with the following conditions (considered the most appropriate to avoid the deterioration of sugars): a temperature of 60 ° C, for 24 hours. This method is

- applicable to solid, liquid, or pasty foods (beating of the panela) not susceptible to degradation when subjected to temperatures above 105 °C [9], [11]. The humidity obtained for our study case was: 2,6%.
- Determination of Density: According with the NTC 852 norm, the density obtained was: 0,54 gr/cm<sup>3</sup>.
  - Determination of the sieve surface and the amount of material to be sieved: The sieving is carried out in an oscillating medium together with a rotary system, where the same axis provides the power to carry out the two tasks, using blades for the rotary and a cam for the oscillating system. The sieve selected for the prototype is 1mm. It is estimated that the quantity to be sieved is 95% of the initial material since there is an evaporation of the water contained in the shake and another part that can remain impregnated on the walls of the container.
  - Analysis of the best method to grind the lump: The lumps are produced by the moisture retained in the granulated panela, causing a high cohesion between the particles, it was estimated that the best method is a combination of an oscillating system to guarantee the passage of the finest particles and rotary movement to eliminate accumulations. that are retained by moisture (lumps).

Finally, a functional prototype was set up about the panela pulverized machine shown in Figure 22.



Figure 22. Functional prototype of the pulverized panela machine

### 3. Conclusions

Evaluating the performance of the machine with respect to other proposals by different authors, is possible to affirm that three of the processes (aerated, pulverized, sieved) can be compacted in a single machine, while the others suggest three different machines to execute each process.

Regarding the performance of the designed and construct machine, can be report that it has good operating performance, the design is robust and oversized since the amount of panela mixture expected to be processed by the machine, it worked without problems.

According to the experimental tests carried out with different types of panela mix in different plantations of the sugar cane industry, it was observed that the best mix for the pulverization process is the one that is planted in dry and arid areas. However, beating time and speed are variables relevant to be considered in future works. Also, is necessary to improve anchors of the machine to avoid unwanted vibrations.

### Acknowledgements

This work is supported by the Directorate of Investigations of the Universidad Autónoma de Bucaramanga, where the research project has a grant to supports Bachelor's students in mechatronics engineering, in design of machines and automation.

## References

- [1] G. Rodriguez, H. Garcia, Z. Roa, and P. Santacoloma, "Producción de panela como estrategia de diversificación en la generación de ingresos en áreas rurales de América Latina.," *Fao*, p. 98, 2004.
- [2] W. F. Quezada-Moreno, W. D. Quezada-Torres, and M. Proaño-Molina, "Evaluación del impacto ambiental en el proceso de elaboración de panela mediante el Análisis de Ciclo de Vida," *Afinidad*, vol. 78, no. 592, pp. 62–67, 2020.
- [3] N. M. Zarate, W. Bokelmann, and F. A. P. Ariza, "Value chain analysis of panela production in utica, Colombia and alternatives for improving its practices," *Agron. Colomb.*, vol. 37, no. 3, pp. 297–310, 2019.
- [4] A. D. Rincón-Quintero, L. A. Del Portillo-Valdés, A. Meneses-Jácome, C. L. Sandoval-Rodríguez, W. L. Rondón-Romero, and J. G. Ascanio-Villabona, "Trends in Technological Advances in Food Dehydration, Identifying the Potential Extrapolated to Cocoa Drying: A Bibliometric Study," *Lect. Notes Electr. Eng.*, vol. 763 LNEE, pp. 167–180, 2021.
- [5] M. Rodríguez-Entrena, M. Salazar-Ordóñez, R. Cordón-Pedregosa, and J. L. C. Cardenas, "Analysing granulated brown sugar- panela- market in Western Honduras," *Br. Food J.*, vol. 118, pp. 495–512, 2016.
- [6] R. Ramón, K. Beltrán, L. Verdezoto, A. Remache, and F. Bayas-Morejón, "Preparation and marketing of granulated panela in family businesses from caluma (Ecuador)," *Food Sci. Technol. (United States)*, vol. 8, no. 4, pp. 73–78, 2020.
- [7] A. S. Bermúdez Carmona, "Plan de exportación de panela orgánica pulverizada como endulzante hacia España," 2021.
- [8] M. C. Castro-Cañon, "Oportunidades de la panela colombiana en la Unión Europea," 2020.
- [9] H. Jair and V. Chaves, "Aproximación a la problemática de la producción de panela en el municipio de Topaipí - Cundinamarca," *Rev. Investig. Opinión Pública*, pp. 67–79, 2018.
- [10] A. D. Rincón-Quintero, L. A. Del Portillo-Valdés, A. Meneses-Jácome, J. G. Ascanio-Villabona, B. E. Tarazona-Romero, and M. A. Durán-Sarmiento, "Performance Evaluation and Effectiveness of a Solar-Biomass Hybrid Dryer for Drying Homogeneous of Cocoa Beans Using LabView Software and Arduino Hardware," *Lect. Notes Electr. Eng.*, vol. 762 LNEE, pp. 238–252, 2021.
- [11] M. M. Ordoñez-Díaz and L. V. Rueda-Quiñónez, "Evaluación de los impactos socioambientales asociados a la producción de panela en Santander (Colombia)," *Corpoica Cienc. y Tecnol. Agropecu.*, vol. 18, no. 2, pp. 379–396, 2017.
- [12] O. A. Mendieta-Menjura and H. Escalante-Hernandez, "Análisis experimental de la evaporación del jugo de caña de azúcar en película sobre una placa plana," vol. 14, pp. 113–127, 2013.
- [13] C. Beltrán Martínez, "Evaluación De Técnicas Para Gestión De Los Residuos De La Producción Panelera (Cachaza) En La Vereda Nacaderos Municipio De Quebradanegra-Cundinamarca," 2020.
- [14] J. G. Maradey Lázaro, H. S. Esteban Villegas, and B. J. Blanco Caballero, "Finite Element Analysis (FEA) for Optimization the Design of a Baja SAE Chassis," *ASME 2018 International Mechanical Engineering Congress and Exposition*. 09-Nov-2018.
- [15] G. Garrido Silva, J. M. Arguello Espinosa, J. G. Maradey Lázaro, G. A. Bayona Velasco, and A. D. Suescun Mejia, "Design and Construction of a Posterior Walker for Older Adults 'Movielinic,'" *ASME 2020 International Mechanical Engineering Congress and Exposition*. 16-Nov-2020.
- [16] G. Garrido-Silva, J. G. Maradey-Lazaro, A. D. Rincón-Quintero, O. Lengerke-Pérez, C. L. Sandoval-Rodríguez, and C. G. Cardenas-Arias, "Estimation of the Energy Consumption of an Electric Utility Vehicle: A Case Study," *Lect. Notes Electr. Eng.*, vol. 763 LNEE, pp. 257–272, 2021.
- [17] B. Fajardo N, D. Molina D, J. Ospina M, and H. García B, "Determinación de algunas propiedades físicas y mecánicas de la panela granulada," *Ing. e Investig.*, vol. 1, no. 43, pp. 34–39, 1999.