

Structural assessment of an existing steel frame building for adding new story by linear static analysis

Safaa Hamdan¹

¹ Civil Engineering, Al-Muthanna University

ABSTRACT

The primary objective of this work is to assess the condition of an existed structural steel frame building that is already occupied by users, and to investigate the load bearing capacity of the major structural members (beams, columns) of the steel frames, so that to find out the possibility of added additional new story that can help to increase the capacity of the building. It was decided by the authorities and the building officials to add another story to accommodate an expansion to increase the occupancy capacity of the building. Structural analysis of the building frames due to original loads would be implemented and then additional story would be added, on the other hand a structural analysis would be performed due to additional story (additional loads). Linear static analysis in both cases was done and responses was evaluated by Demand to Capacity Ratios (DCR), And by a comparison the DCR for columns in both cases, it was found that the bearing capacity of columns allow to add new story safely. Furthermore, redesign of the new building would be carried out using commercial software sap2000. The building façade, such as veneers and curtain walls are not considered as structural elements therefore, not covered in this work. (The connections of joints and foundation analysis would be covered in farther considerations using another finite element program).

Keywords: Assessment, Existing Building, Steel Frame, DCR

Corresponding Author:

Safaa Hamdan
Al-Muthanna University,
Iraq
E-mail: safaa.hamdan@mu.edu.iq

1. Introduction

Evaluation and assessment of existing structural buildings is a major topic in construction working. Where rehabilitation including repairs, upgrading and expansion construction works represent almost half of all construction activities. Assessment is needed for several circumstances including, a change in ownership or to accommodate an expansion or modification or change of occupancy or use, usually in these cases, no reason for concern is known at the outset. Where no damages identification is found, a preliminary assessment may be sufficient. An assessment where damage or deterioration is suspected or already appeared due to earthquake, fire, impact, aggressive environment, low quality building materials or building systems with a known deterioration history may require detailed assessment [1]. Many existing structures do not fulfil requirements of currently valid standards; therefore, assessment and evaluation of existing buildings often requires knowledge overlapping the framework of standards for the design of new structures. Engineers carry out an assessment must have knowledge and experiences such as; properties of material, durability and environmental reactivity of construction materials, previously construction methods and the new technologies in this scope and failure mechanisms of structures [2]. The engineers who implement structural condition assessment of existing buildings are engaging in a specialized area of professional practice and they should seek the advice of legal counsel and insurance professionals to assist them in undertaking any risks. Building owners, government agencies, building officials and the public may rely up on the results of the practitioner's inspection. If their assessment fails to discover a serious defect or flaw, consequently a structural failure or building collapse can occur, they may be held accountable for the damages. However, the current codes almost exclusively scope the



construction and erection of new structural building. Therefore, they can be applied to a limited extent for construction in existing building only. For technical purpose the codes that used in design and construction the specific building is necessary to assess that building [3]. There are some guidelines provide guidance on professional practice for Engineering Professionals who carry out structural condition assessment of existing building. These guidelines are not intended to provide systematic instructions for how to carry out these activities; rather, these guidelines outline considerations to be aware of when carrying out these activities [4]. There are three types of assessments may be undertaken during a structural condition assessment of existing buildings; preliminary assessment (assessments which include review of record documents, field evolution, preliminary analysis and material assessments. The preliminary assessment should also confirm whether a detailed assessment is recommended or farther review is required to address specific issues). Detailed assessment (which requires grater details and more accuracy to increase the reliability of the resulting recommendations). Limited scope assessment (that intended to address specific structural elements of the building. The preliminary assessment must give details such as; understanding the building's layout and its primary structural system, understand the geotechnical and soil conditions of the site, identify the originally specified design loads in relation to current loading and proposed usage, identify material specifications such as; strength and grade. The assessment methodology would be vary depending on physical building configurations. The techniques that used for such works may range from a visual review to destructive sampling and testing. There could be some difficulties in conducting a visual inspection because some of the main structural elements in a building bay be covered by finishes. Therefore, it is the engineer expert professional judgment to determine which covered area should be exposed for inspection and where would be the critical elements. The engineering computation may be required to verify the adequacy of the critical elements. And these calculations usually use approximate methods. These calculations can identify the member's situation and recorded in qualitative terms from 'excellent', through 'good' to 'fair' or 'poor'.

2. Methodology

An inspection visiting to the building was conducted for preliminary assessment. Prior that a review of all relevant documents and drawings. A visual inspection was conducted to verify the adequacy of the primary structural systems to the extent possible using non-destructive methods. The assessment includes the member geometry; material type; Then identification of the building conditions was undertaking by survey the structural construction defects; signs of structural damages; distress or deformations or deterioration. And it was obvious that all the members were 'good' and intact, there were no damages or deterioration. The actual service life of the building is almost 6 years, it was constructed in 2014. The building was originally designed of two stories (ground and 1st floor) to be occupied by the staff of the faculty (teachers, students and employees). The frames of the building are made up of steel sections (beams and columns) with composite concrete slabs and supported by raft foundation (as it shown in Fig-1). Then it was decided to add new story (as 2nd floor) to increase the capacity of the building [5]. Therefore, an assessment condition structural was undertaking to find out the potential of the existing steel frames building for additional new story by using commercially available program software, Sap2000 for structural analysis. This study presents Linear Static Analysis of three dimensional 2-storied steel frames due to gravity loads (live loads and dead loads), and then redesign was conducted for 3-storied steel frames, depending on the data (geometry and material properties) that available in the actual planes and sketches. Then finding out the DCR (Demand to Capacity Ration). The DCR can be calculation for beams depending on the ratio of the maximum moment in the beam to its ultimate capacity:

$$DCR = \frac{M_{max}}{M_p} \quad \dots\dots(1)$$

Where:

M_{max} is the effect of action for the applied loads (maximum moment in the beam), whereas M_p is the ultimate moment capacity of the beam (plastic moment).

For DCR of columns, it be calculated using the following equation:

$$\frac{P}{P_y} + \frac{M_{pc}}{1.18M_p} \leq 1 \quad \dots\dots(2)$$

Where:

P is the axial forces, and P_y is the yield strength of axially loaded section, whereas M_{pc} is the effect of action of the applied load (maximum moment acting in a member).

3. Load combination and

For Linear Static Analysis, the following load case is performed according to ACI code:

$$(1.2 D. L + 1.6 L. L)$$

The self-weight of the building is automatically taken into account by the program depending on the properties of the materials and the geometry. The thickness of the slab is 150 mm.

The gravity loads are specified as in table (1) as the following:

Table 1. Applied loads

Applied loads on the Ground floor	
Uniformly distributed dead load.	4KN/m ²
Uniformly distributed live load.	5KN/m ²
Uniformly distributed line load on the perimeters (walls).	6KN/m
Applied loads on the Roof floor	
Uniformly distributed dead load.	5KN/m ²
Uniformly distributed live load.	3KN/m ²
Uniformly distributed line load on the perimeters (brick walls).	18KN/m

4. Material properties

The material mechanical properties are specified in table (2) as the following:

Table 2. Material properties

Materials	Mechanical properties	Actual values
Concrete	Compressive strength (f_{cu})	35 MPa
	Poisson's ratio	0.2
	Unit weight	24KN/m ³
	E	$4700\sqrt{f_{cu}}$
Reinforcement	Min. yield stress	400
	Tensile strength	600
	Poisson's ratio	0.3
	Unit weight	78 KN/m ³
	E	200,000 MPa
Steel section (beams and columns)	Min. yield stress	250
	Tensile strength	410
	Poisson's ratio	0.3
	Unit weight	78 KN/m ³
	E	200,000 MPa

5. Geometry of the existing building (original plans and sketches)

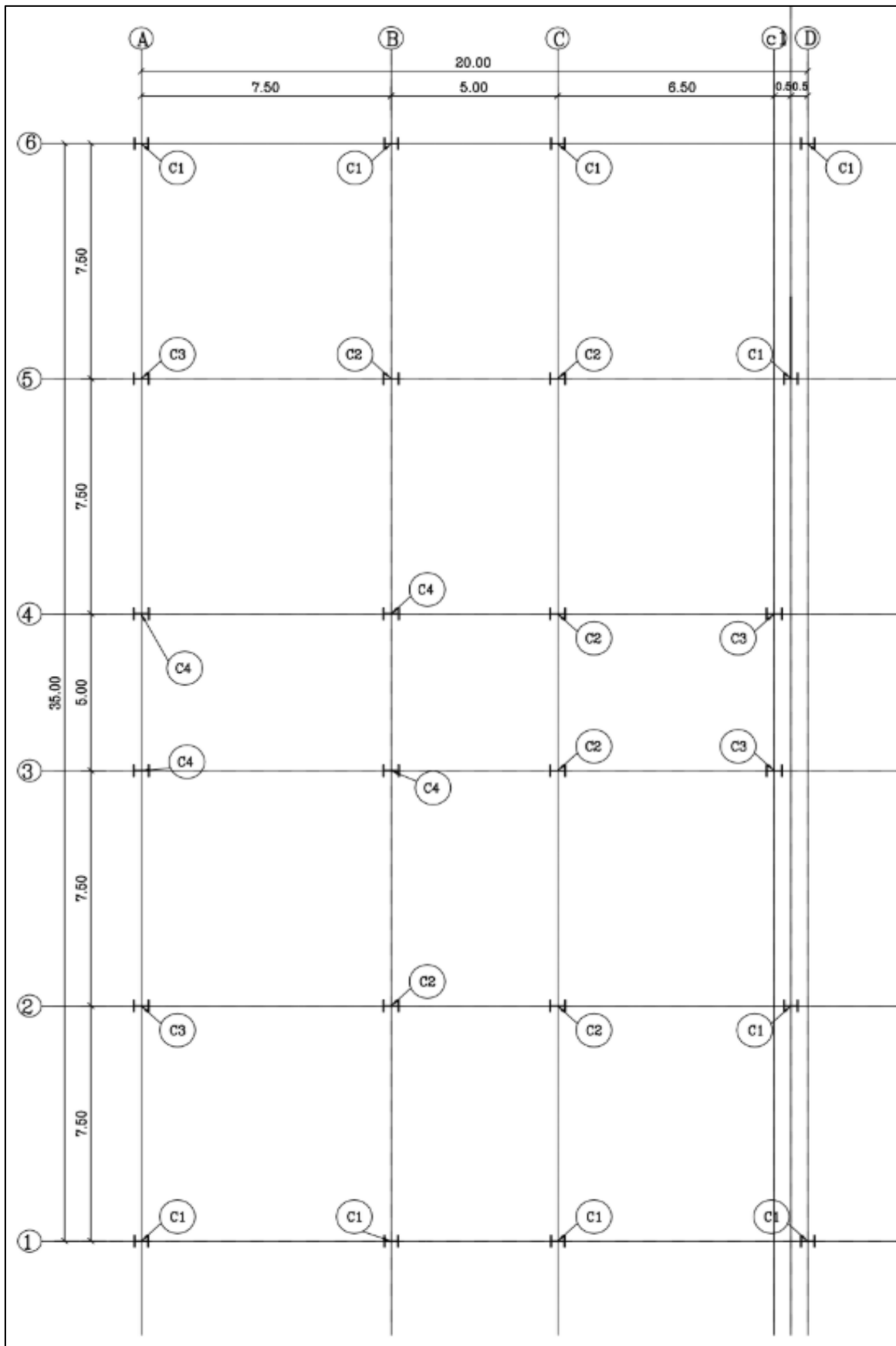

Figure 1. General layout of the actual building

Figure 2. Outer side frame of the building

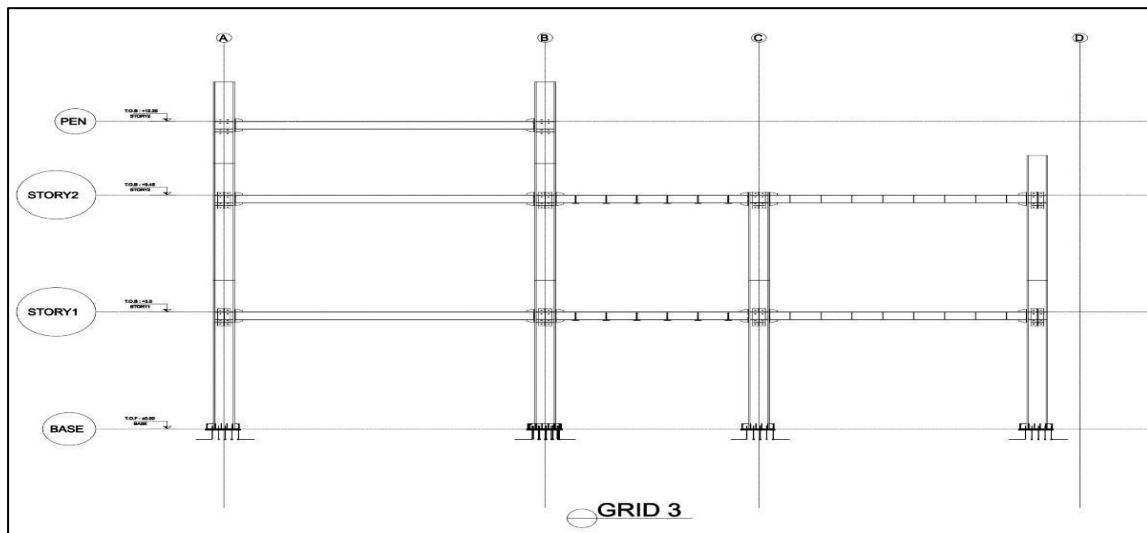
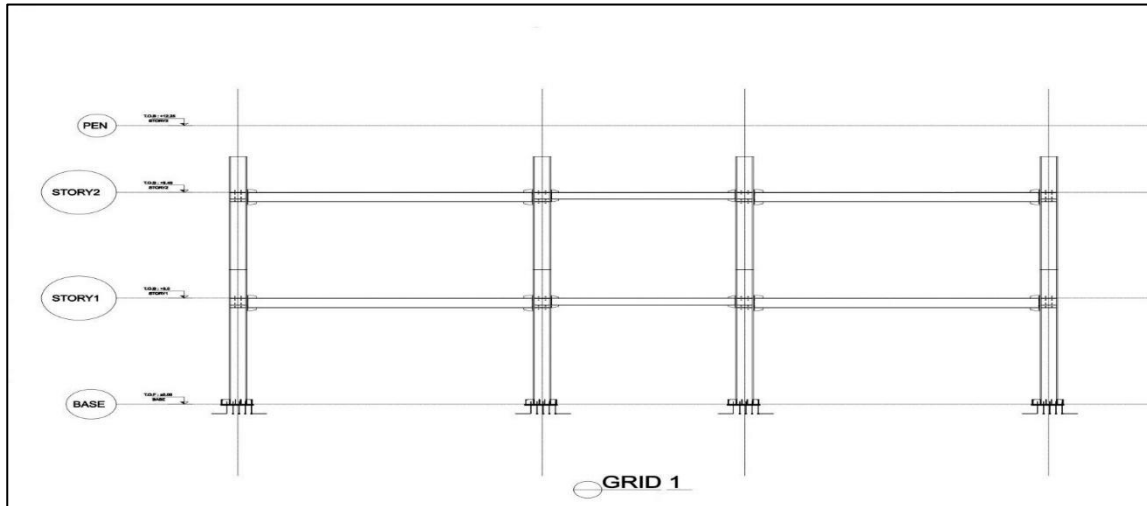

Figure 3. Middle frame of the building

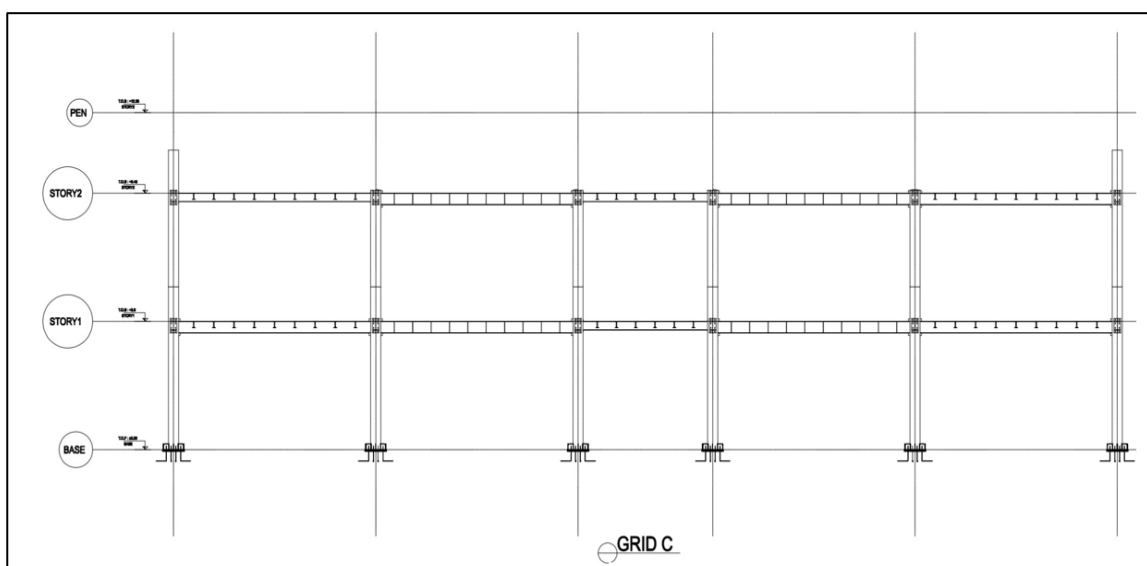

Figure 4. Back view frame of the building

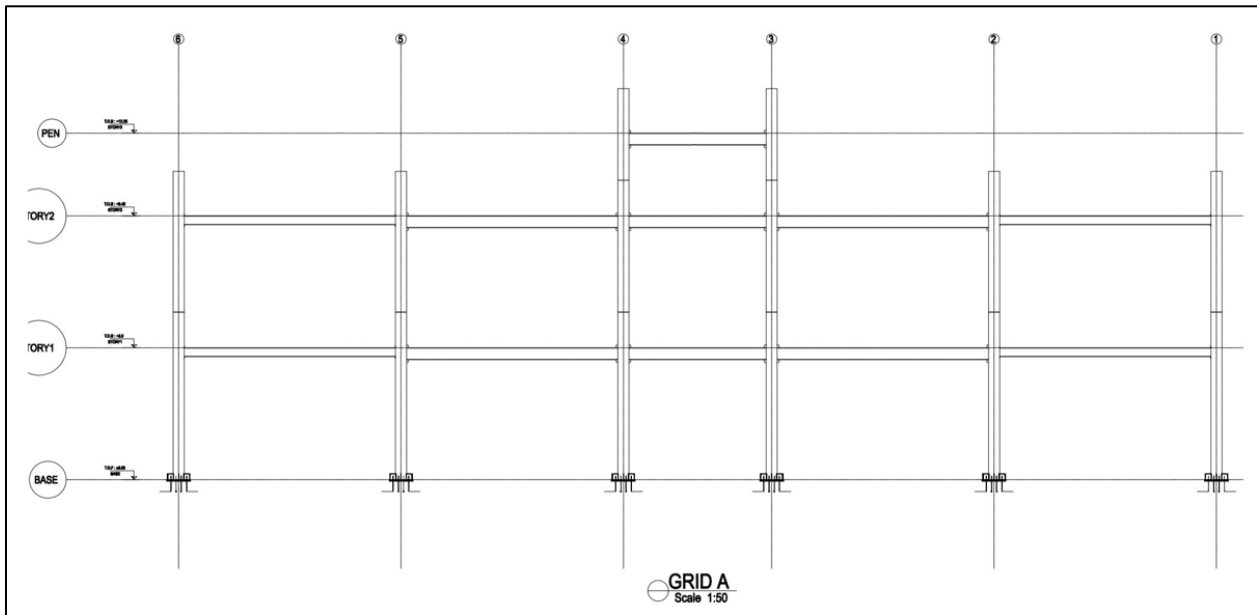

Figure 5. Front view frame of the building

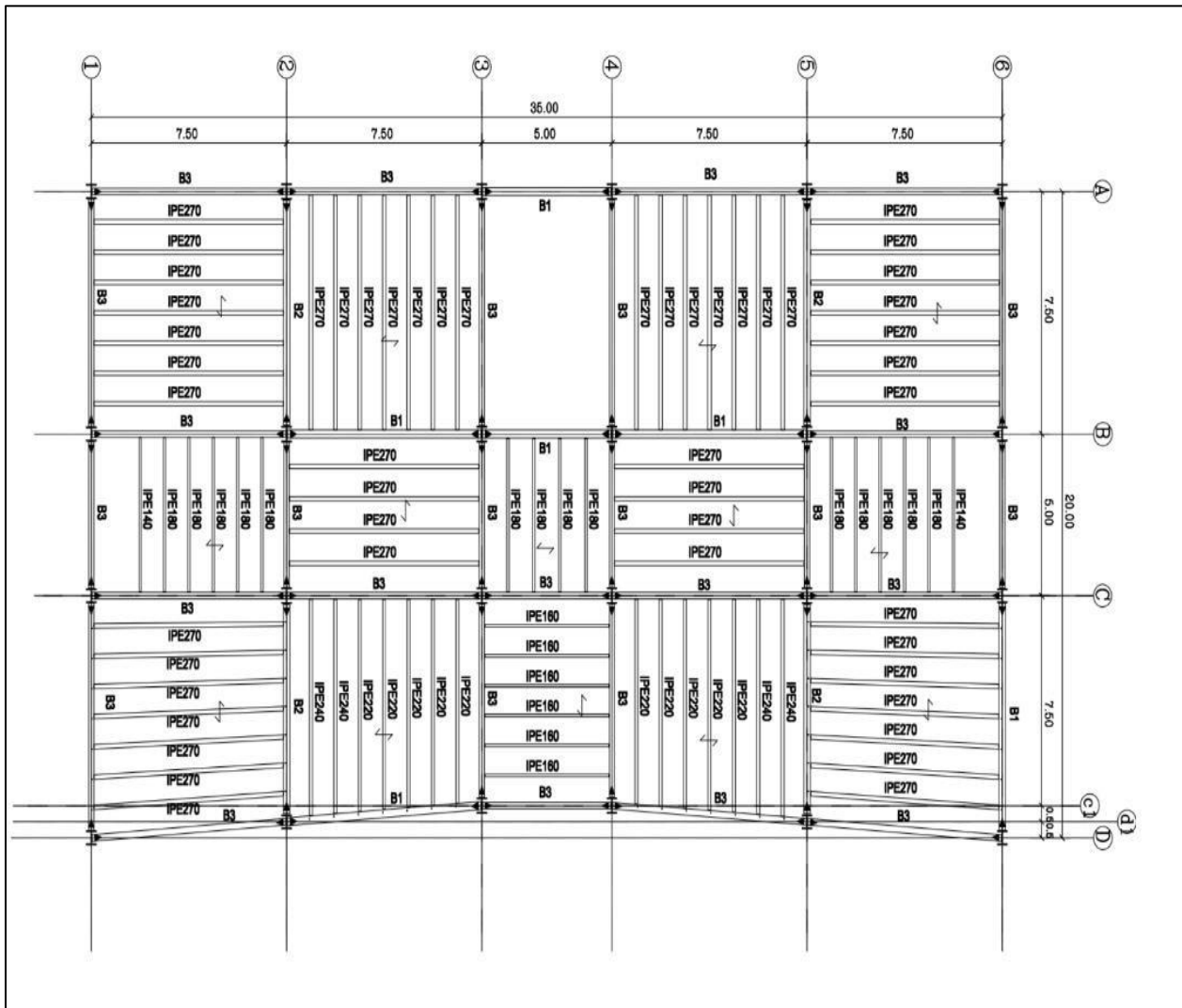

Figure 6. Rooms layout of the actual building

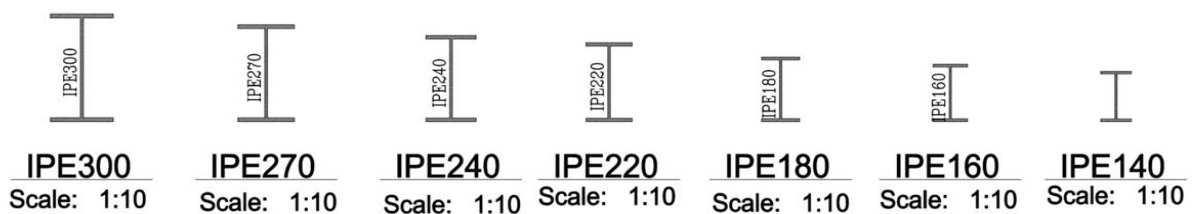

Figure 7. Cross- sections of the beams

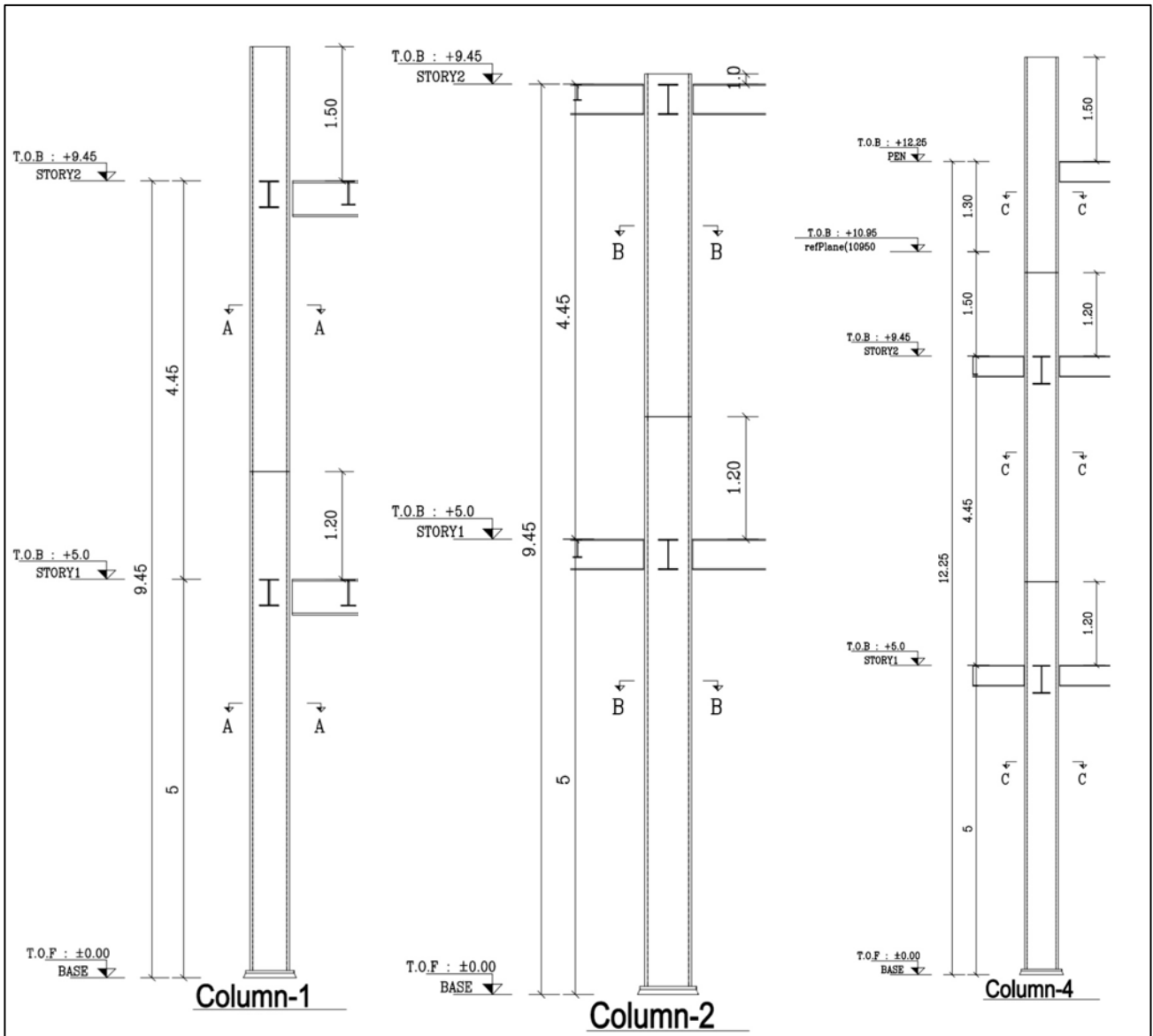

Figure 8. Columns' geometry

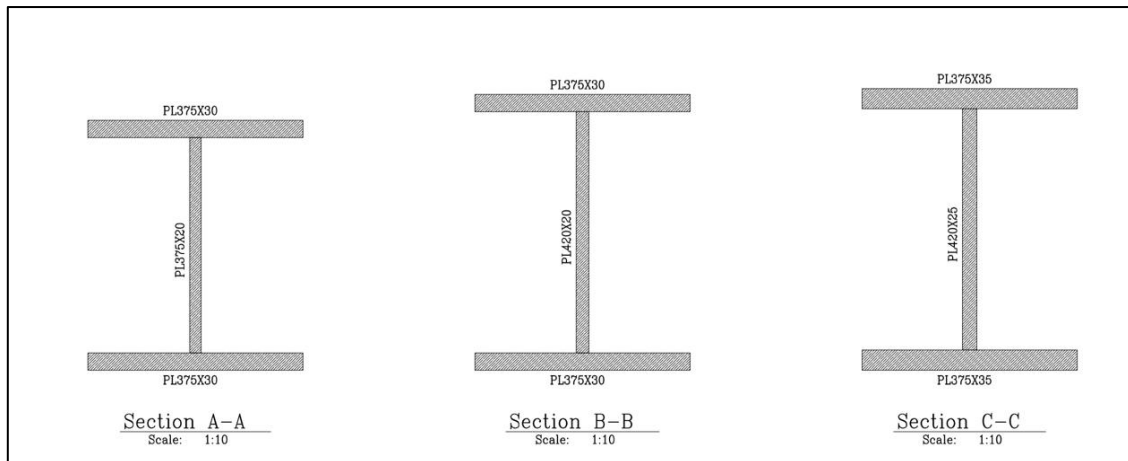

Figure 9. Cross- sections of the columns

Table 3. General frame sections properties

Section Text	Shape Text	t3 mm	t2 mm	tf mm	tw mm	t2b mm	tfb mm	Area mm ²	I33 mm ⁴	I22 mm ⁴
B1	SD Section							11250	329273438	39093750
B2	SD Section							16475	473092323	57394322.92
B3	SD Section							7008	113606784	16011776
COL.1	SD Section							30000	1012218750	263921875
COL.2-3	SD Section							30900	1264230000	263951875
COL.4	SD Section							36750	1515631250	308164062.5
IPE140	Flange I/Wide	140	73	6.9	4.7	73	6.9	1640	5410000	449000
IPE160	Flange I/Wide	160	82	7.4	5	82	7.4	2010	8690000	683000
IPE180	Flange I/Wide	180	91	8	5.3	91	8	2390	13170000	1010000
IPE220	Flange I/Wide	220	110	9.2	5.9	110	9.2	3340	27720000	2050000
IPE240	Flange I/Wide	240	120	9.8	6.2	120	9.8	3910	38920000	2840000
IPE270	Flange I/Wide	270	135	10.2	6.6	135	10.2	4590	57900000	4200000
IPE300	Flange	300	150	10.7	7.1	150	10.7	5380	83560000	6040000

6. Connection

The analysis is totally depending on the input parameters of the engineer who build the geometry model and run the analysis. Hence, according to the original plans and documents of the building, the connections of all the secondary beams and all the primary beams are pinned connection. And the connections of the columns with the foundation are fixed connection. It was used different sizes of bolts with welded plate stiffeners at the joints. Therefore, releasing moment at the ends of the beams was used (all the beams are considered as simply supported).

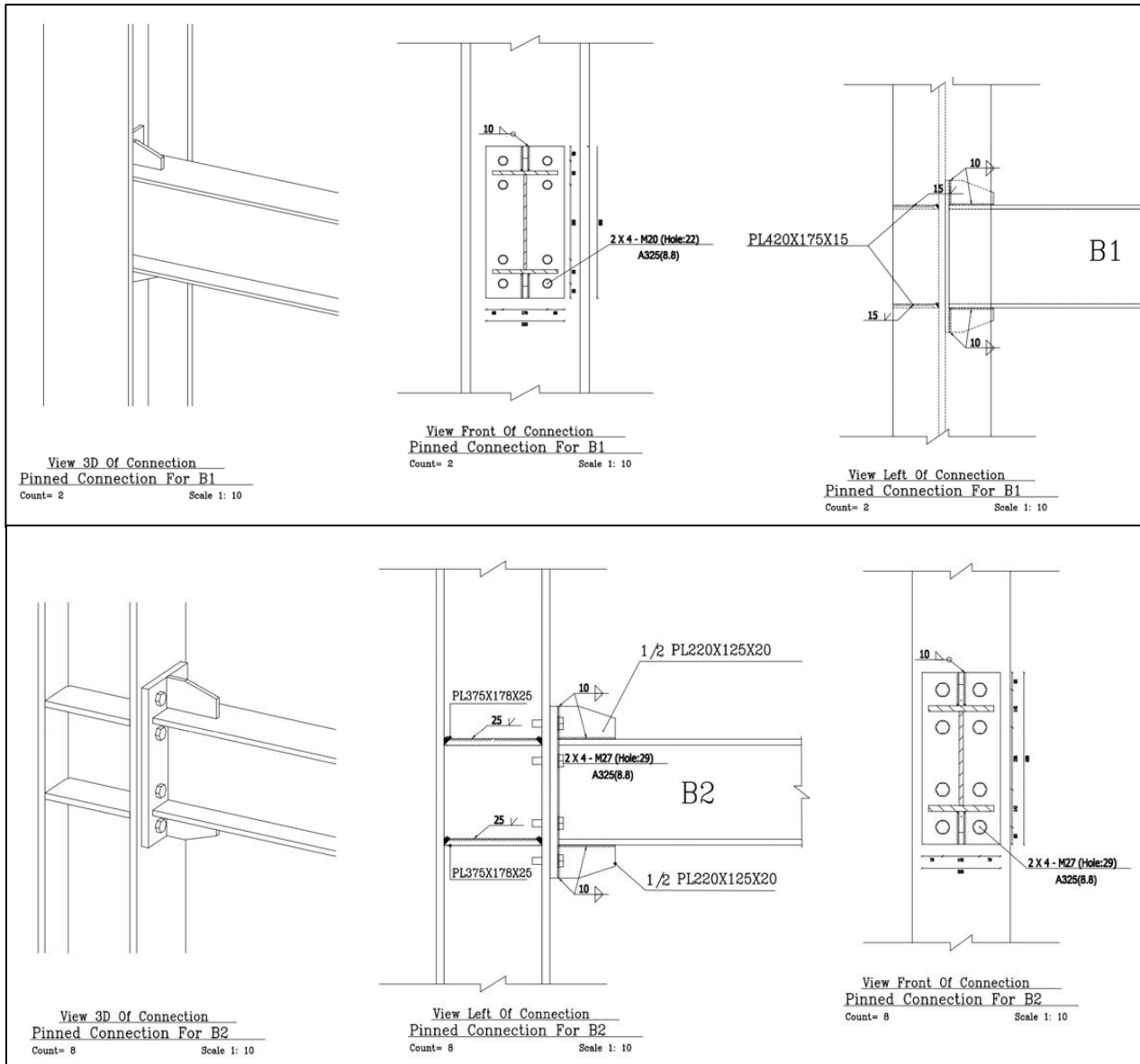

Figure10. Primary beams connections

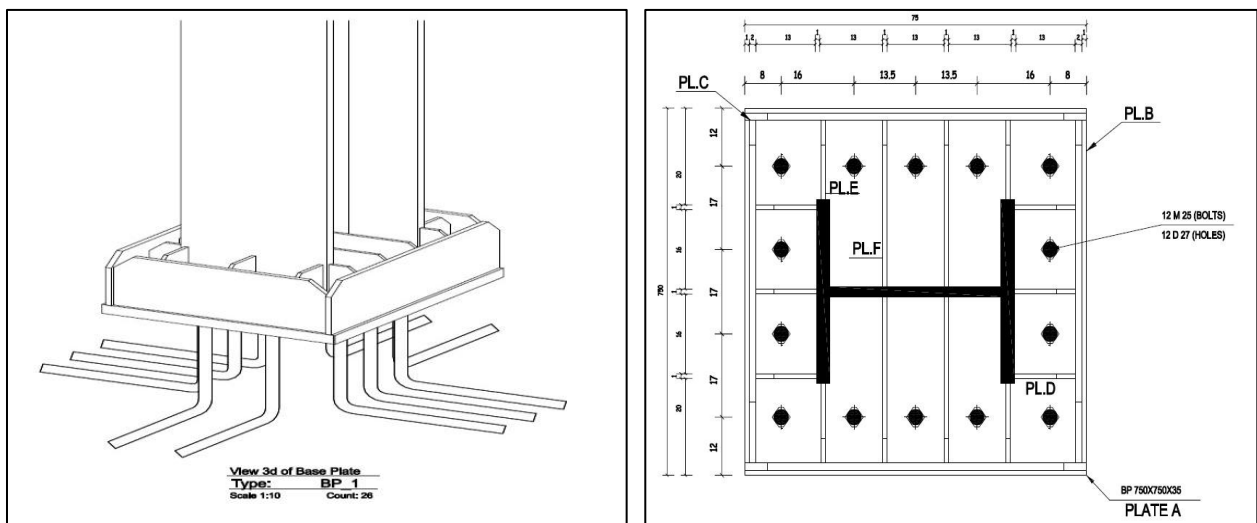

Figure 11. Column-Raft connection

7. Structural analysis of the steel frame

A preliminary analysis is not intended to be a comprehensive analysis of the building; however, engineering computation may be required to verify the adequacy of critical elements and structural system. These calculations typically use approximate methods and should focus on the suspect area or element of the building, to determine if the conditions identified in the document review. These calculations can identify a need for immediate action or farther investigations, or could provide a satisfaction that the system is adequate.

Linear Static Analysis for three-dimensional structural frames is done using Sap2000 software [6]. Depending on all the parameters that given in the actual plans and the material properties that given from the laboratory tests. Most of the steel sections are built-up (main beams and columns), while the secondary beams are standard which are available in the library of the program. Section-designer has great role to utilize the built-up sections in the Model. The responses are determined by finding Demand to Capacity Ratios (DCR):

1- The structural analysis procedure explicated in the following steps:

- Building the geometry model of the actual building.
- Apply the actual gravity loads and line loads.
- Perform static linear analysis using a standard procedure available in sap2000.
- Finding the internal forces.

2- Redesign of the building is performed to check the actual load carrying capacity by checking the (DCR) for each member.

After checking all members, it is found that the existing building is safe for the present and future depending on the actual load.

3- Then a new story is added (has the same material properties and dimensions). And again, linear static analysis is done to find the internal forces for the specific load case.

4- Redesign for the default 3-storey is performed.

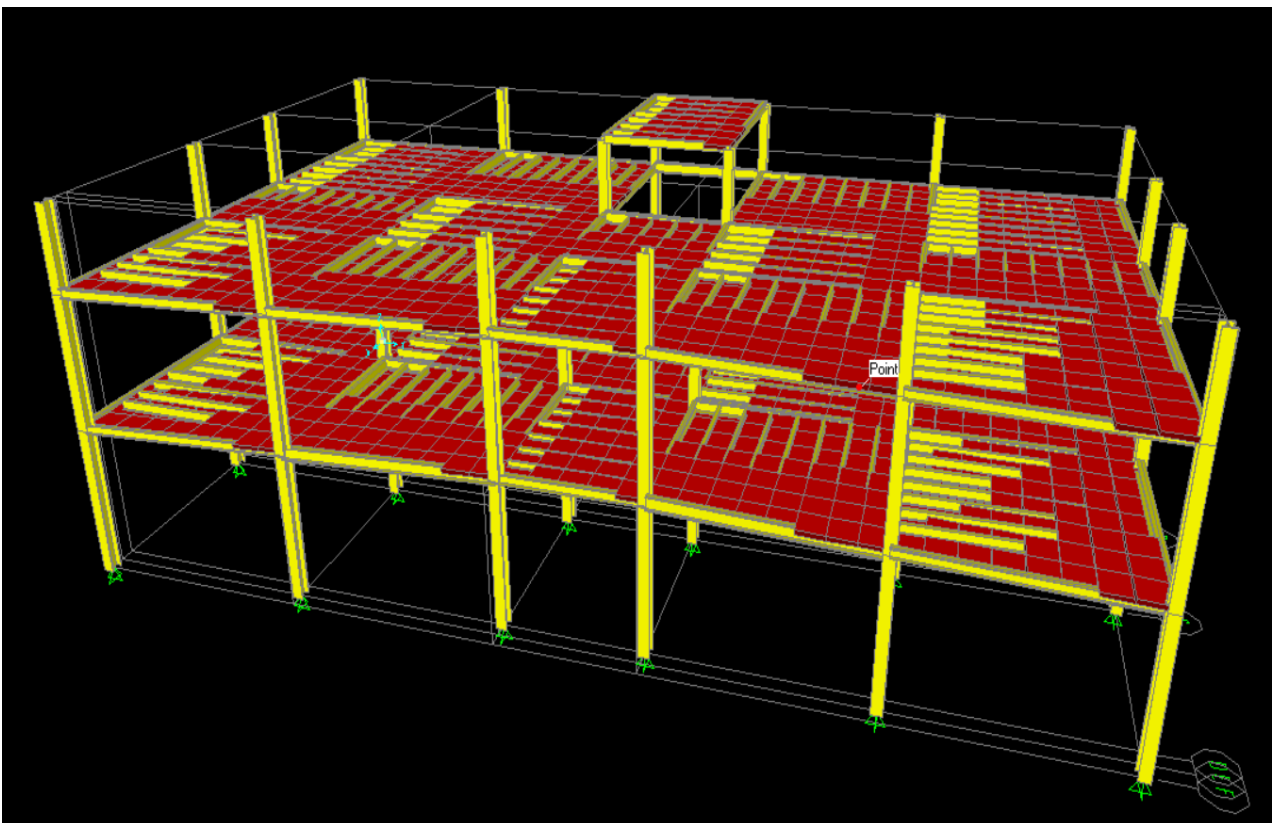

Figure 12. Geometry model of the actual building

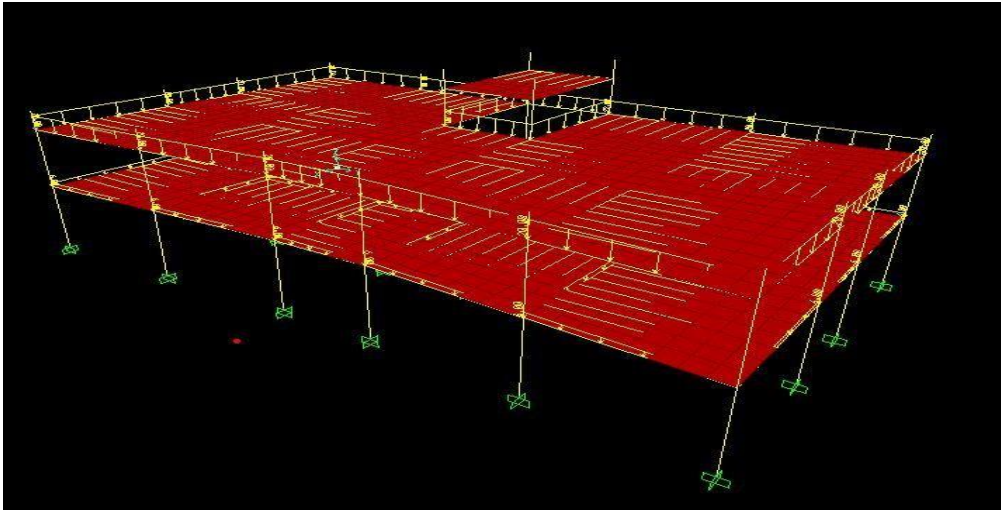

Figure 13. Applied line loads on walls

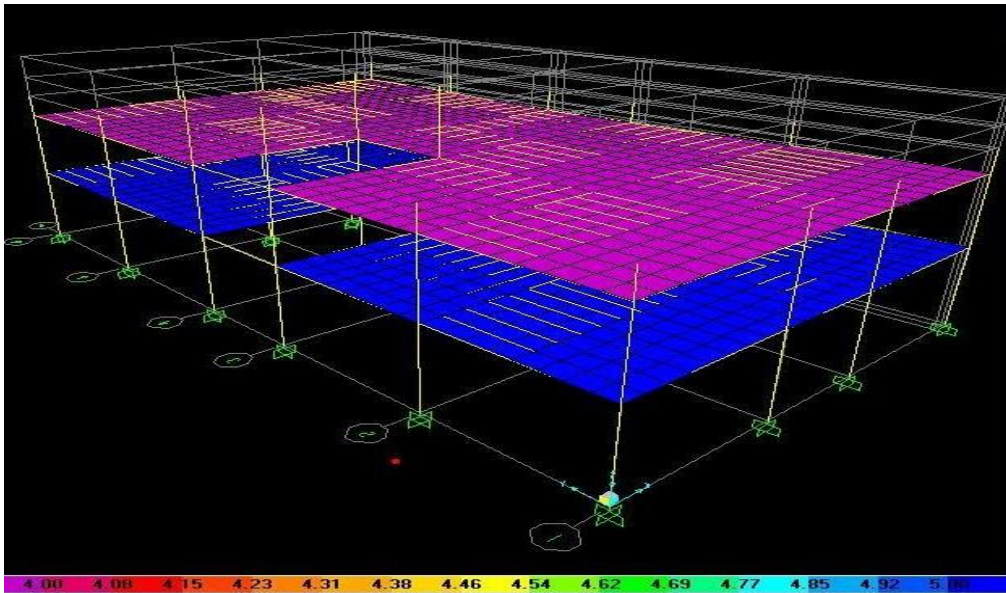

Figure14. Applied Live Loads (area load)

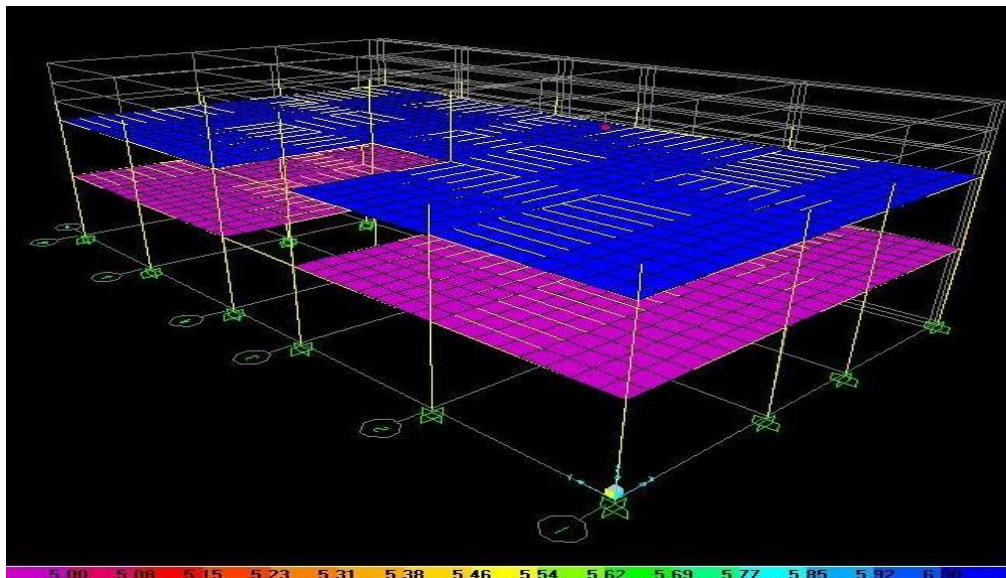

Figure 15. Applied Dead Loads (area load)

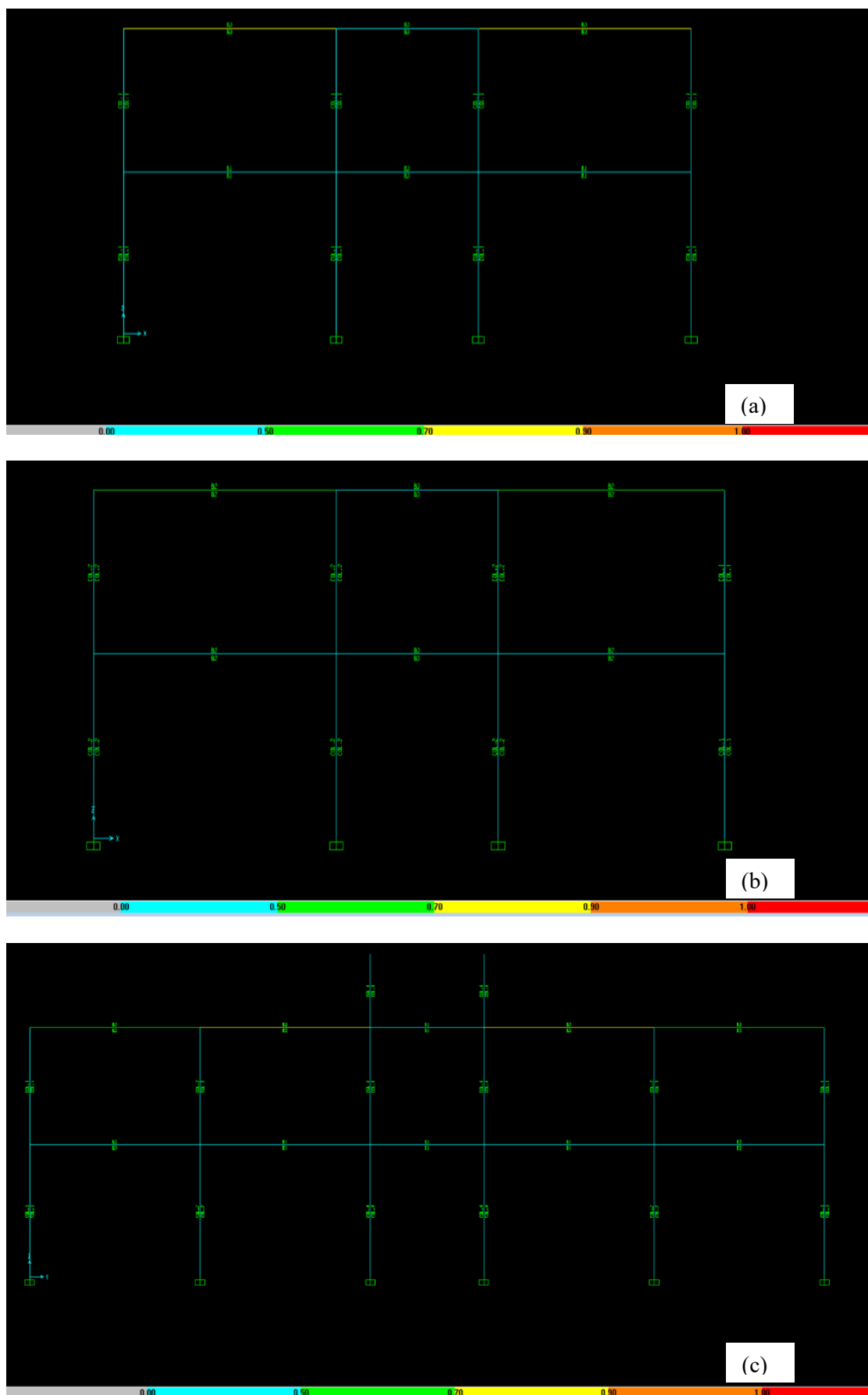

Figure 16. (a - b - c). DCR of primary beams and columns for original building (two-story)

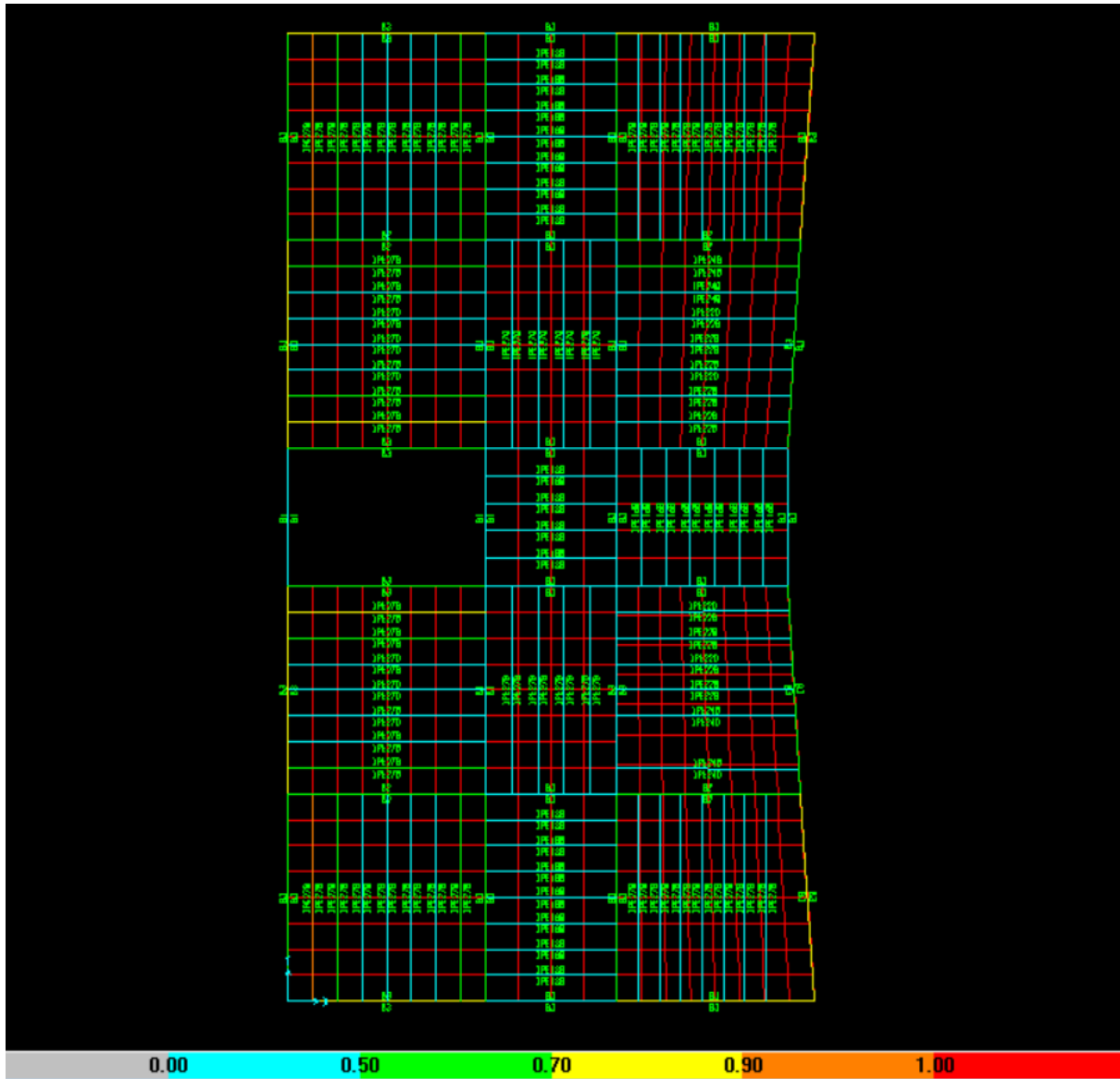

Figure 17. DCR of secondary beams of floors

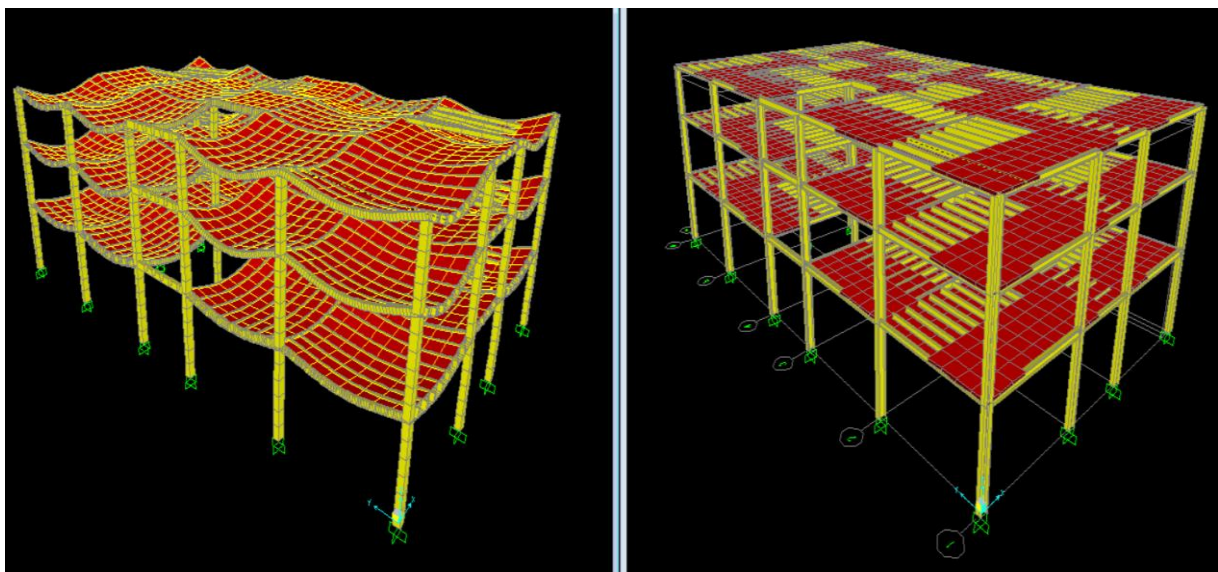

Figure 18. Geometry model of the new added story

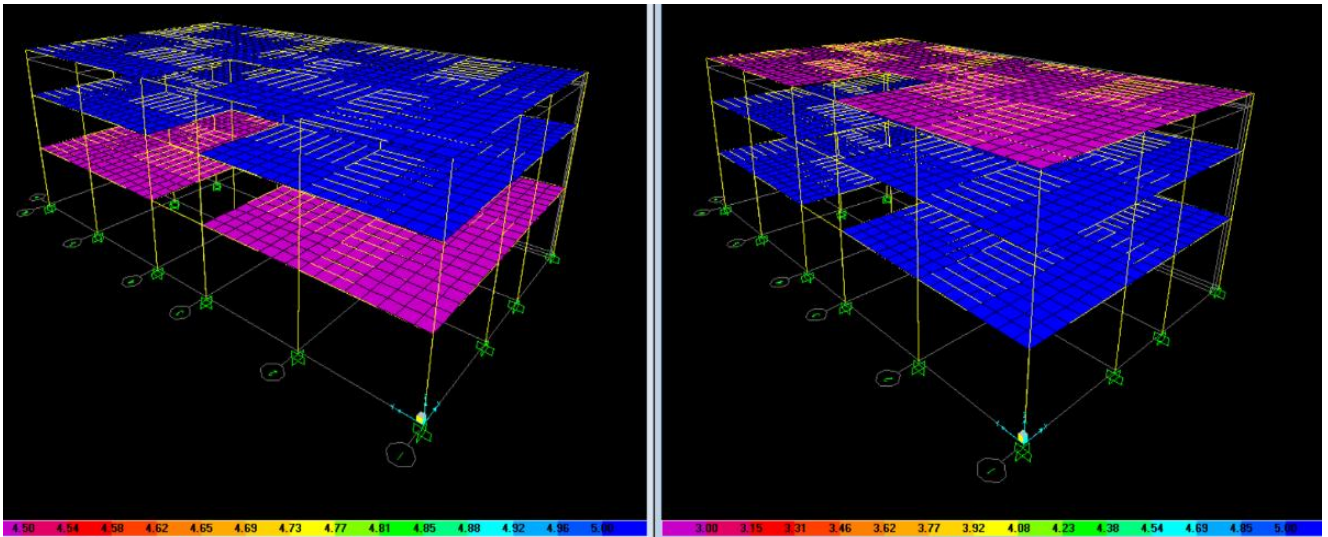

Figure 19. Applied dead and live loads

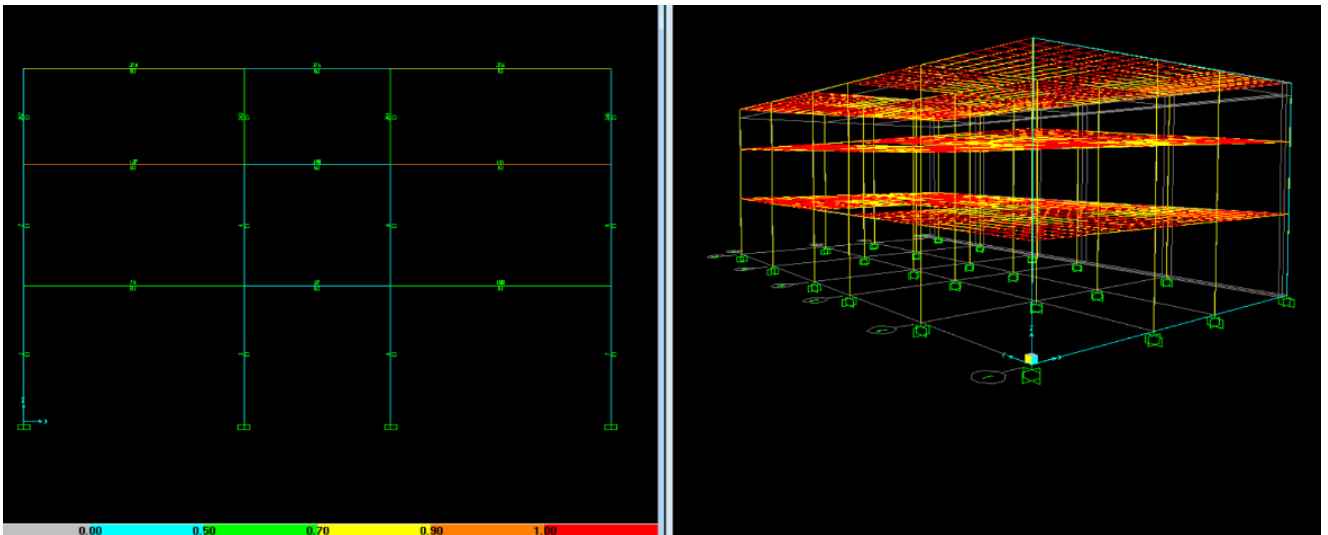

Figure 20. DCR of beams and columns after adding new story
External frame; XZ-plane @ Y=0 m

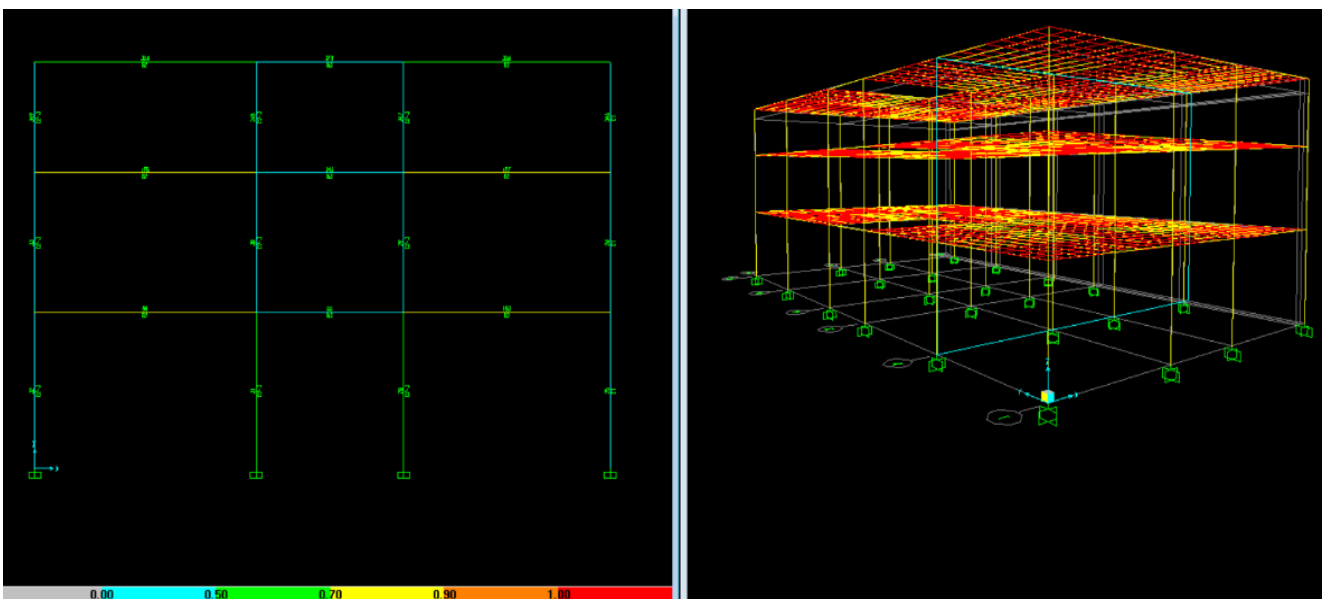

Figure 21. DCR of beams and columns after adding new story
Internal frame; XZ-plane @ Y=7.5 m

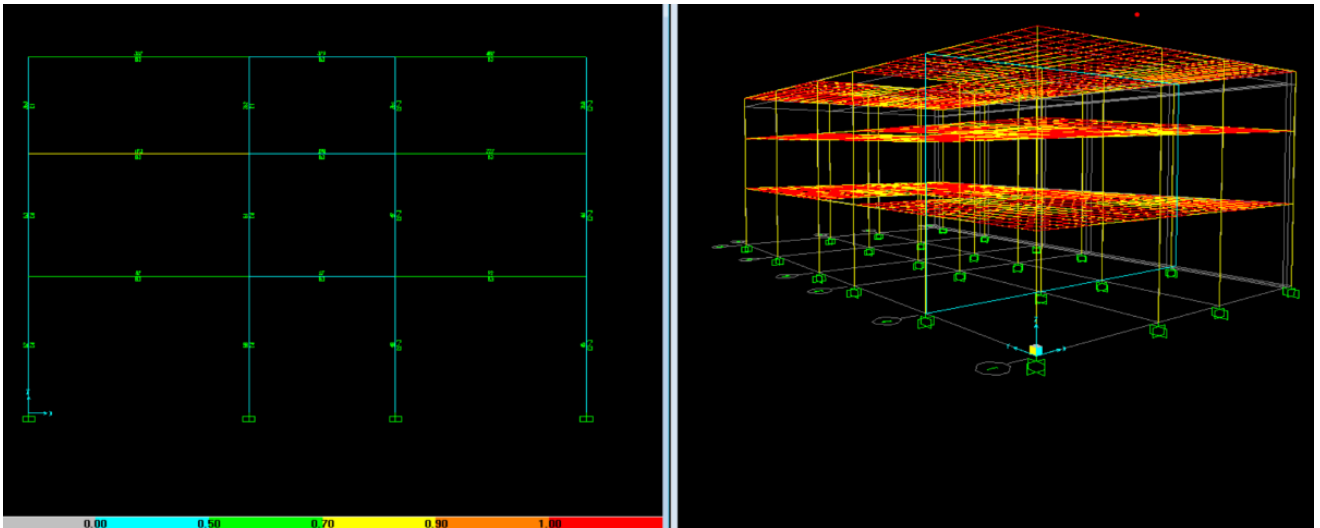

Figure 22. DCR of beams and columns after adding new story
Internal frame; XZ-plane @ Y=15 m

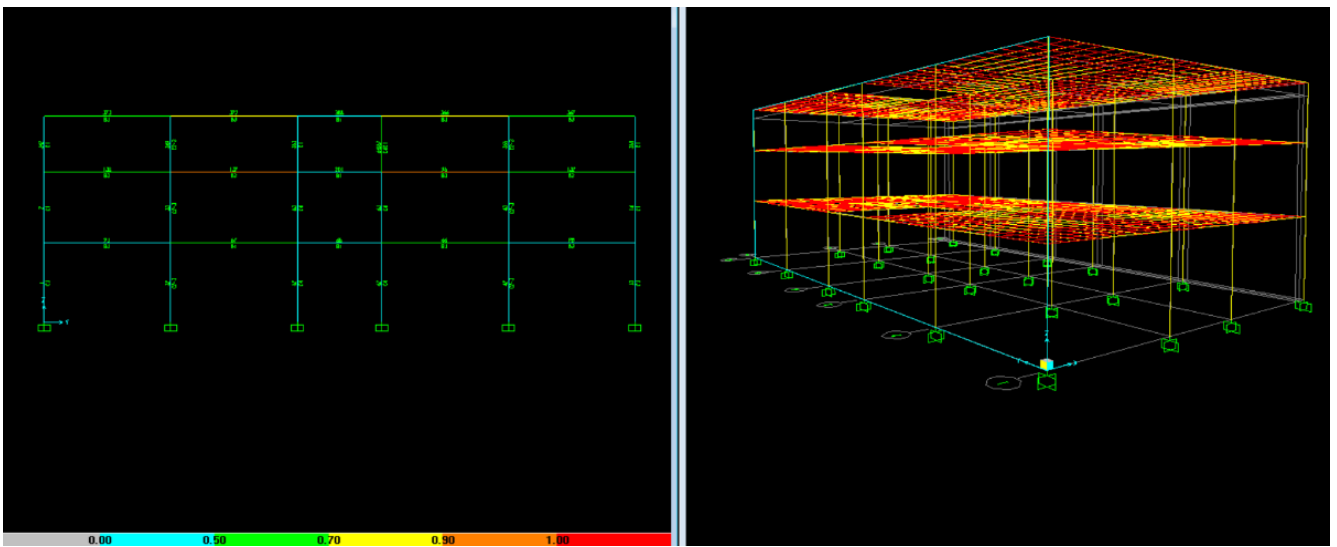

Figure 23. DCR of beams and columns after adding new story
External frame; YZ-plane @ X=0m

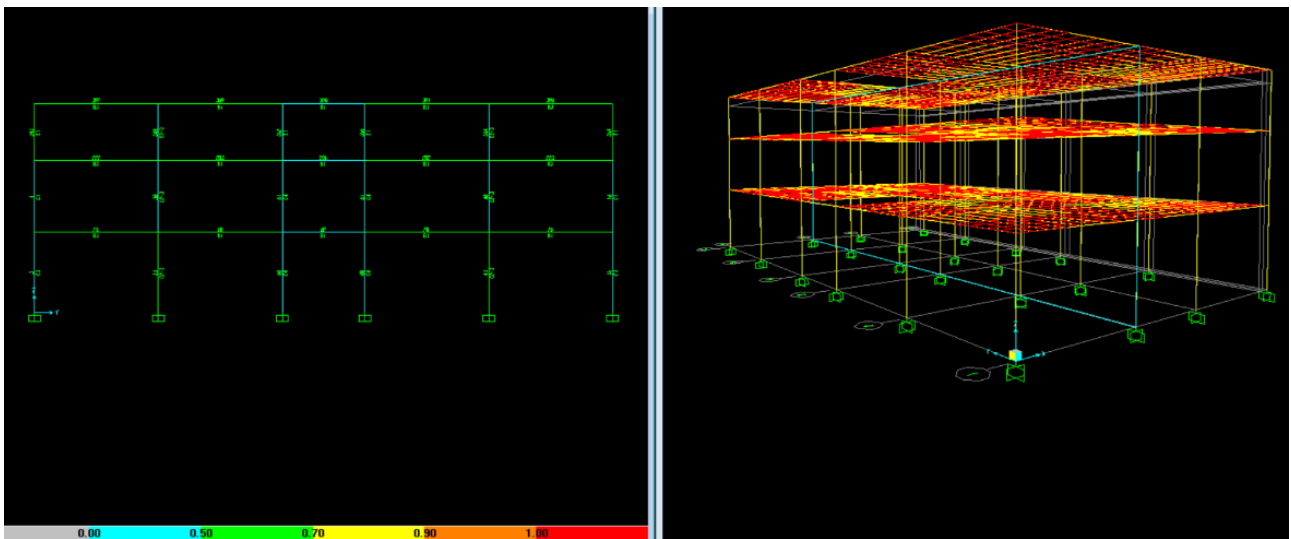

Figure 24. DCR of beams and columns after adding new story
Internal frame; YZ-plane @ X=7.5m

8. Results

As it shown in the original plans of the buildings, the steel frame is symmetrical about x-axis, therefore, half of the building is considered. The values of DCR of the columns are obtained (DCR can be calculated manually using the formulas (1) and (2), or can be obtained directly from the program after run linear static analysis and redesign) and a comparison between two cases are made. Firstly, DCR for columns of two-floor building, secondly DCR for columns of three-floor building as it shown in table (4). frame sections properties. The values of DCR for beams are not needed in the comparison because it doesn't affect the results, only a modification of live load from 3KN/m² to 5KN/m² for the 2nd floor is done. And it was obvious the DCR for the all beams don't exceed the permissible limit. The results can be represented as bar chart using Microsoft Excel (number of columns versus DCR) as it shown in figure (25).

Table 4. Comparison of DCR - for columns

Number of Columns	DCR (2 floors)	DCR (3 floors)
col.1	0.129	0.214
col.3	0.243	0.47
col.5	0.262	0.45
col.7	0.149	0.24
col.25	0.322	0.47
col.26	0.284	0.381
col.28	0.403	0.585
col.29	0.224	0.42
col.30	0.186	0.38
col.31	0.4	0.59
col.32	0.285	0.434
col.33	0.262	0.35
col.45	0.136	0.32
col.46	0.32	0.225
col.48	0.256	0.4
col. 49	0.269	0.323
col.50	0.243	0.452
col.51	0.352	0.331
col.52	0.13	0.21

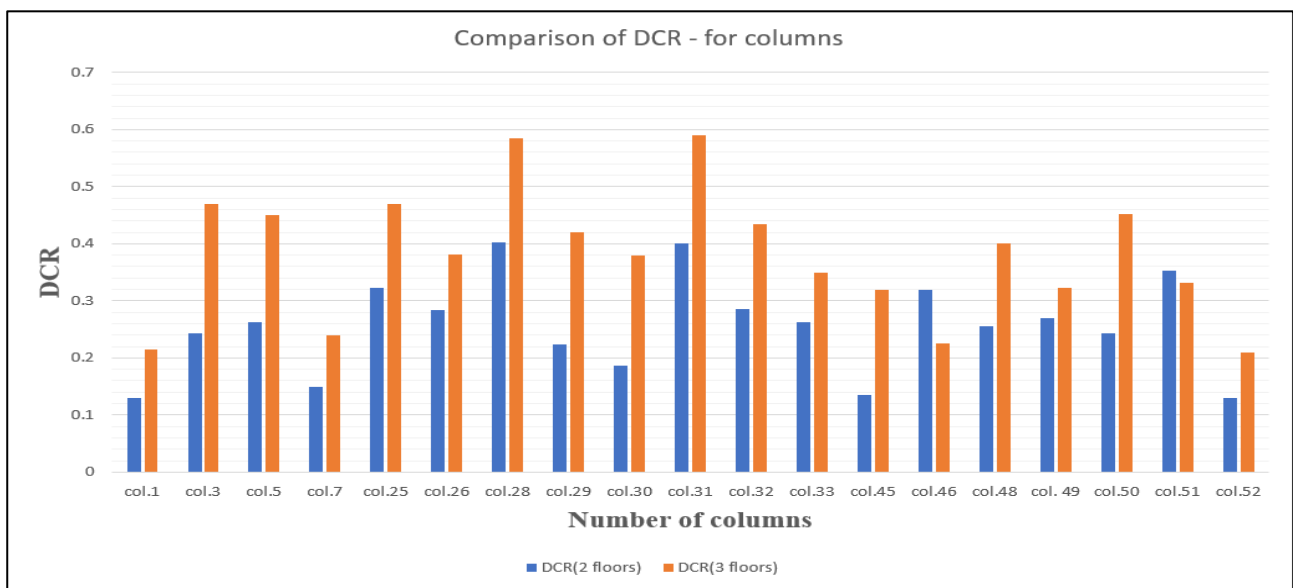

Figure 25. Comparison of DCR – for columns

9. Discussion

An assessment of existing building should be very accurate, all the plans and documents of original building should be studied carefully and clearly specify the input parameters of the program, the material properties and all the dimensions and geometry of the building must be determined as it shown in the plans. In this case an existing low-rise steel frame building consists of two floor system was in need to general evaluation. Therefore, after building the geometry mode, identify the mechanical properties of the materials and applying the gravity loads, three-dimensional linear static analysis was run. Studying the internal forces and moments in all secondary and primary structural members in load cases. Then, using the ultimate load combination to redesign the building in two cases to give the final decision for adding new floor to the actual building or not. Depending on the results to use decided that the actual building has good structural system and there was no any flaw or degradation, so it is save to add the new story.

10. Conclusions

After performing linear static analysis and redesign in both cases (two-floor and three-floor), DCR was calculated, by the program, for columns doesn't exceed the permissible limit at any floor, the values of DCR for columns are governed the comparison. Hence, columns don't fail in this analysis. It was very obvious the building is saved for its existing loads (the beams and columns are totally intact and the bearing capacity has lower values). Due to these lower values, it is recommended to add a new floor to increase the occupancy capacity of the building. And as it was mentioned the beam does not affect the results but the values are obtained to ensure that the bearing capacity doesn't exceed the permissible limits.

11. References

- [1] N. Karl Becker, D. Ireland, N. Kennedy, R. Nathwani, B. Ross, "Structural Condition Assessments of Existing Buildings and Designated Structures Guideline," November 2016.
- [2] Structural Engineers Association of British Columbia "Structural Condition Assessment of Existing Buildings," British Columbia, December3,2020
- [3] A. Newman, "Structural Renovation of Buildings, Methods, Details, and Design Examples, Second Edition," America, 2020
- [4] K. Losev, G. Chulkov and V. Chulkov, " Comprehensive assessment of options for renovation of buildings and city blocks," International Conference on Sustainable Cities, IOP Conf. Series: Earth and Environmental Science 177 (2018) 012026.
- [5] P. Patel and R. Parikh, " Various Procedures for Progressive Collapse Analysis of Steel Framed Buildings," the IUP Journal of Structural Engineering, Vol. VI, No. 1, January 2013, pp. 17-31.
- [6] SAP2000, Analysis Reference Manual, Version 11, Computers and Structures Inc., Berkeley, Calif.