

## Enhancement of the efficiency of solar energy cells by selecting suitable places based on the simulation of PV System

Faisal Theyab Abed<sup>1</sup>, Hisham Dawood Salman Altai<sup>2</sup>, Hussein Tuama Hazim<sup>3</sup>,  
Haider TH. Salim ALRikabi<sup>4</sup>

<sup>1,4</sup>Department of Electrical Engineering, College of Engineering, Wasit University, Wasit, Iraq

<sup>2,3</sup>Department of Electrical Engineering, College of Engineering, University of Misan, Misan, Iraq

### ABSTRACT

At present, the increasing demand for electrical energy and the presence of renewable sources in various forms in the world and, particularly in Iraq, such as solar energy and wind energy, have become the focus of researchers' attention. Huge efforts are focused on finding ways to use ecologically friendly energy to generate electricity and eliminate fossil fuels. In this study paper, we propose the use of a simulation program to discover the ideal location for a solar cell and the amount of time to be exposed to the sun's rays, so that a home powered by solar energy can be built. Also, through this program, the losses were calculated that accompany the conversion of light energy into electrical energy to find the necessary solutions to make the solar cell work with high efficiency.

**Keywords:** Renewable energy, solar energy, smart technologies, PV sys., PV array

### Corresponding Author:

Faisal Theyab Abed  
Department of Electrical Engineering  
College of Engineering, Wasit University  
Wasit, Iraq  
ftheyab@uowasit.edu.iq

### 1. Introduction

A photovoltaic system can be called a solar energy system, is a system designed to convert usable solar energy by installing photovoltaic cells [1, 2]. It consists of a group of components, including solar panels that stand for the most important of these components, whose function is to absorb and convert sunlight into electrical energy, and a device for converting electrical power from direct current to alternating current, to which cables and other electrical accessories are added to create an integrated working system. Solar tracking and integrated battery solutions have enhanced the overall efficiency of the intended system since storage device prices are predicted to fall [3, 4]. Accordingly, only the visible portion of the photovoltaic system (the solar array) is included in this definition. The design of photovoltaic systems can be small systems that are installed on the roofs of public buildings or home buildings or integrated systems with modern technologies and also can be installed in buildings and have production capabilities Ranging from a few to several tens of kilowatts, to huge power plants on the scale of electric power fields of hundreds of megawatts [5-7]. Presently, the majority of the PV systems are interconnected to the electrical grid. In contrast, off-grid or standalone PV systems represent a small part of the market. Photovoltaic systems work cleanly and quietly, without any moving parts or environmental emissions accompanying their work, so they can be considered production stations without ecological impact. Therefore, technology has become a priority to develop, use, and move away from traditional production methods [8, 9]. Consequently, these electrical energy facilities have evolved from specialized and small market applications to mature technology and giant projects used to generate electrical power [10, 11]. For example, a solar cell on a roof provides around 95% of net clean, renewable energy throughout 30-year service life. Because of the rapid



growth of solar cells, the cost of photovoltaic systems has decreased significantly since their inception. Depending on the market and system size, they can vary considerably. Residential 5 KW systems in the US cost about \$3.29 per watt in 2014, while rooftop systems up to 100 kW cost €1.24 in Germany, where the market is well-developed. System components and concessional fees (customer acquisition, permits, and inspections), installation work, and finance charges make up the rest of the cost. PV modules account for less than half of the system's cost.

Table1. Electricity supply/demand (1991 – 2010)

Year	Power supply (Mw)	Power demand (Mw)
1990	9000	5000
1991	5000	6000
2002	5500	7000
2003	4500	3500
2004	4000	5500
2006	4500	7000
2008	5000	10000
2010	8500	15000

This table clearly shows that Iraq has a large electricity supply-demand gap, widening over time due to rising consumer demand for electrical goods and Iraq's industrial expansion. Air conditioner consumption throughout the summer, which lasts from May to the end of September [12-14], causes an Iraqi Ministry of Energy shortage of about 6000 MW, according to the MoE.

### 1.1. Weather in Al-kut city

Kut's summers last around six months and are marked by heat, dryness, wind, and a lack of clouds, while the city's winters are chilly, dry, and largely clear. Throughout the year, the temperature usually ranges from 7°C to 46°C and rarely below 3°C or above 49°C. The figure below shows the climate summary [15].

Table 2. The climate in Kut city

Month	Weather condition	The amount of rain	Humidity
Jan-Apr	Cloudy-partly cloudy	25-30 mm	Muggy
May –Aug	Clear	0 mm	Dry
Aug –Dec	Cloudy-partly cloudy	25-30 mm	Muggy

There is an average daily temperature above 40°C from late May through September, with the hottest day of the year being July 27, when the average temperature is 46°C and 31°C, respectively. A daily maximum temperature of fewer than 24 degrees Celsius can be expected from November to the beginning of March. January 11 is the coldest day, with an average temperature of 7 to 18 degrees Celsius [16, 17]. **Table 3** below shows the average temperature.

Table 3. Average of temperature in kut city

Month	Average temperature	Type weather	Month	Average temperature	Type weather
January	6-20	Cool	July	31-46	Hot
February	10-22	Cool	August	35-50	Hot
Mars	14-25	Moderate	September	25-38	moderate
April	18-32	Moderate	October	20-36	Cool
May	25-43	Hot	November	12-26	Cool
June	28-45	Hot	December	10-20	Cool

In Kut, the average percentage of cloudy skies has significant seasonal variation throughout the year. When the sky is 100% clear, most days of the year in the city start at the end of May and last 4 months or are partly cloudy time, primarily overcast or cloudy. Clear weather is very encouraging for investment in solar panel investment and design.

## 2. Related work

Solar photovoltaic technology, a clean and green kind of energy generation, is critical in meeting the country's energy needs. Multiple researchers have carried out photovoltaic modeling and simulation studies over the last decade utilizing various methodologies and simulation tools to analyze numerous parameters [18-20]. As a result, Ada et al. created an IP10P solar PV model using Matlab and Labview to produce PV panel evaluation tools for testing the model in a summer outdoor environment [21]. In [22], the authors used empirical data and a curve fitting method to create solar PV module I-V and P-V characteristics. The problem with this method is that it can't collect adequate data if there is no experimental setup. This means that developing and modeling characteristic curves is challenging. These models show the functional and behavioral properties of PV generators, which also thoroughly analyze experimental results with simulation results. Matlab simulations of a circuit-based solar PV model for varying radiation and temperature values were provided by specific authors [23, 24]. However, these articles do not detail a particular subsystem in the final solar PV model. It is mathematically possible to calculate the multiple model parameters accurately and thus thoroughly compare experimental and simulated results for PV models by Mohammedi et al. (2013), who presented PV models. The authors also created and tested a photo voltaic-powered water pump. Rahman et al. (2014) used a NIST-supplied polycrystalline PV module model to evaluate the module's output power against the measured output power. Yatimi and Aroudam described mathematical modeling for solar PV modules in a Matlab environment, but the authors do not include PV model modeling [27]. Although Yldran and Tacer (2016) used the elementary central equations in Matlab/Simulink for constructing the solar PV model and compared the simulated consequences with the manufacturer data consequences, the thorough stepwise modeling of PV modules is not included in this research. Matlab/Simulink modeling of monocrystalline PV modules in [29-31] compares outdoor measurements with simulations well. However, it doesn't show the step-by-step evolution of PV modeling. Mendalek and Al-Haddad (2017) used the mathematical governing equation to construct the PV module script in Matlab and identify the model parameters of commercial PV module KC200GT [32]. The characteristic curve has been determined by varying the irradiation and temperature parameters in specific authors' Matlab/Simulink models of PV modules [33, 34]. It is true that Pendem and Mikkili (2018) presented a Matlab/Simulink application for modeling and simulating the KC200GT PV module. Still, they did not describe the phase-wise development of PV module modeling so that readers may run into difficulties simulating and comprehending the model. Based on the research cited above, photovoltaic module modeling, simulation, and analysis still have a long way to go [36, 15, 37]. Solar power might be considered a leading solution to electricity shortages because of its long-term impact on a country's socio-economic development [38]. It's vital to know if and how it can be done with the current infrastructure and resources. Some of the hurdles to the effective deployment of solar energy in the country include a lack of assessment of solar resource data, the need for user-friendly calculation and simulation tools to research the solar generator system, and computation for the proper size of photovoltaic systems. [39].

As a result, software tools for model authentication are needed to go around the obstacle and better comprehend real system behavior. PV system modeling, simulation, and analysis software packages abound, including Solar Pro, PV-Spice, PV-Design Pro, and PV CAD, but there are several disadvantages, such as high costs, commercial exclusivity, interface issues with electronic power systems, and proprietary packages that are only commercially available [40, 41]. Due to its ease of use and high flexibility, the Matlab/Simulink package may be used to address the shortcomings mentioned above. This software is ideal for engineers working in power electronics, solar photovoltaics, and other technical fields. To properly install a PV system anywhere, it is essential to conduct thorough modeling, simulation, and analysis of the solar PV generator [42, 10] beforehand. Researchers have spent the last decade focusing on solar PV module modeling and simulation to get the most accurate findings. Mathematical approaches, analytical methods, artificial intelligence approaches, linearization approaches, artificial neural networks, fuzzy techniques, and evolutionary algorithms [43-45] can model and optimize solar PV modules. Microstrip filters and antennas can be employed for signals and information managements based on assigned bands about the proposed system [46-49].

### 3. Proposed work

In this research, a solar-powered house was equipped with a simulation system to supply the home by installing solar cells on its roof to choose a place to install the solar cells. The installation method reasonably ensures an increase in the efficiency of the solar cell, as depicted in Table 4.

Table 4. Photocell installation parameters

Geographical site	Situation		Time defined	
	Iraq –Kut	Latitude 32.5° N	Longitude 45.8°E	<b>Time zone</b>

When installing solar cells on the specified roof of the house, the quantity of radiation falling on the top of the cell is taken into account, and the expected shade is avoided.

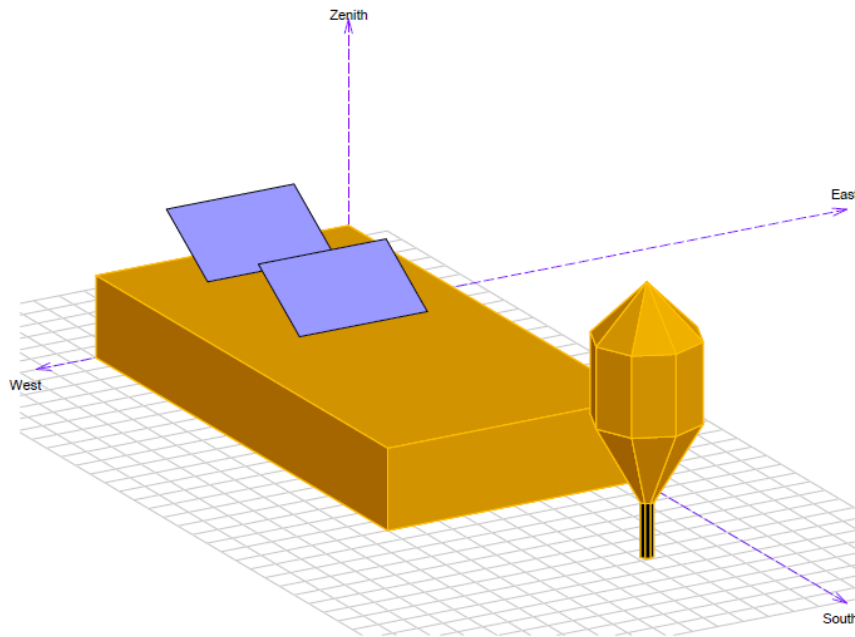

Figure 2. Perspective PV-field and surrounding shading scene

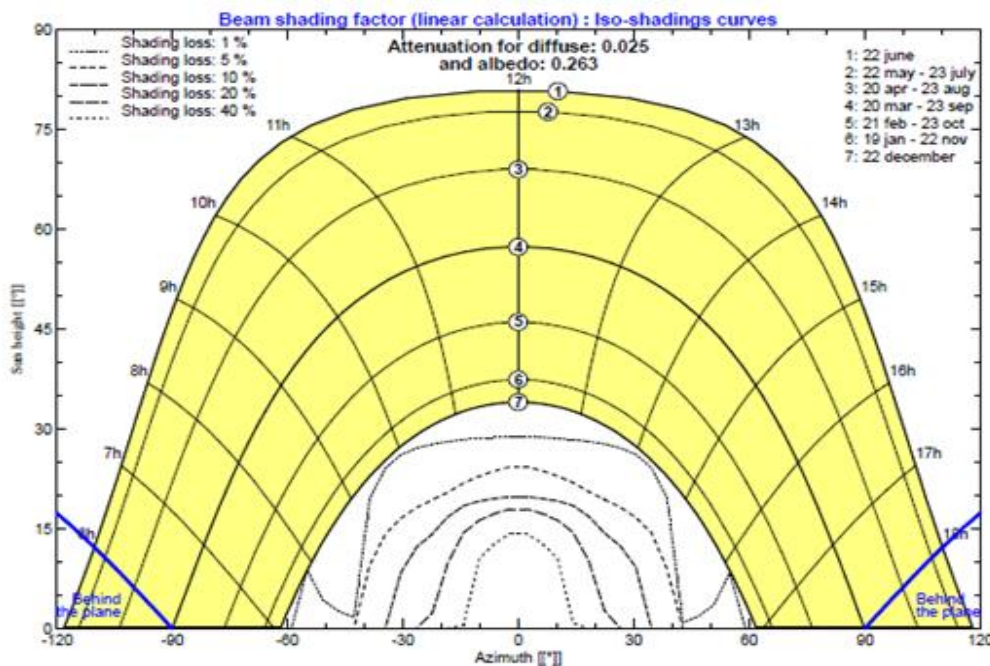

Figure 3. Iso-shadings diagram

Where the virtual house is equipped with photovoltaic cells and used for simulation purposes, as detailed below.

Table 5. PV Array characteristics

PV module		Battery	
Manufacturer	Generic	Manufacturer	Generic
Unit Nom. power	440 Wp	Technology	Lead –acied,vented ,tubular
Number of PV modules	28 unit	Number of units	24 in series
Nominal (STC)	12.32kWp	Discharging min.soc	20.0%
Modules	12 string *2 in series	Stored energy	133.9kwh
Controller		Battery Pack characteristics	
Technology	MPPT converter	Voltage	48V
Temp.coeff.	-5.0Mv/C°/Elem.	Nominal capacity	3488Ah (C10)
Converter		Temperature	Fixed 20° C
Maxi and EURO efficiencies	97.0/ 95.0%	Battery management control	
Back-up genest		Threshold commands	SOC calculation
Manufacturer	Generic	Charging	SOC =092/075
Nominal	1.5 kW	Approx.	53.7/49.5 V
Total PV power		Discharging	Soc =0.2/0.45
Nominal (STC)	12kWp	Approx	46.6/48.3V
Total	28 modules	Back-Up Genset Command	SOC =0.25/0.45
Module area	62.3m <sup>2</sup>	Approx.	47.2/48.3 V
Cell area	55.6 m <sup>2</sup>		

The loads were chosen to simulate the system used to supply the house with solar energy throughout the year. Through these loads, the best site for installing the solar cell is studied, and as a result, its efficiency is known, and the necessary methods are found to increase efficiency For the cell whereas shown below in tables:

Table 6. Detailed User's needs of summer (Jun-Aug)

Loads	Number	Power /w	Use -hour /day	Energy -wh/day
Lamps	10	100w/lap	5	500
Tv/mobile /pc	2	100w/app	5	1000
Domestic application	1	500w/app	4	2000
Fridge	1	200W	24	4800
Dish and cloths-washers	1	2000w	2	2000
Ventilation	1	100w total	24	2400
Air condition	1	1000w total	3	3000
Stand-by consumers	1	6w	24	144
Total day energy				15844 wh/day

Table 7. Detailed User's needs of Autumn (Sep-Nov)

Loads	Number	Power /w	Use -hour /day	Energy -wh/day
Lamps	10	100w/lap	5	500
Tv/mobile /pc	2	100w/app	5	1000
Domestic application	1	500w/app	5	2500
Fridge	1	200W	24	4800
Dish and cloths-washers	1	1000W	2	2000
Ventilation	1	100w total	24	2400
Stand-by consumers	1	6w	24	144
Total day energy				13344 wh/day

Table 8. Detailed User's needs of spring (Mar-may)

Loads	Number	Power /w	Use -hour /day	Energy -wh/day
Lamps	10	100w/lap	5	500
Tv/mobile /pc	2	100w/app	5	1000
Domestic application	1	500w/app	5	2500
Fridge	1	200W	24	4800
Dish and cloths-washers	1	2000w	2	2000
Ventilation	1	100w total	24	2400
Stand-by consumers	1	6w	24	144
Total day energy				13344 wh/day

Table 9. Detailed User's needs of winter (Dec-Feb)

Loads	Number	Power /w	Use -hour /day	Energy -wh/day
Lamps	10	100w/lap	6	600
Tv/mobile /pc	2	100w/app	6	1200
Domestic application	1	500w/app	6	3000
Fridge	1	200W	24	4800
Dish and cloths-washers	1	2000w	2	2000
Ventilation	1	100w total	24	2400
Stand-by consumers	1	6w	24	144
Total day energy				14144 wh/day

#### 4. Results

By studying the expected loads during an entire year, as it was concluded through the illustrative chart below.

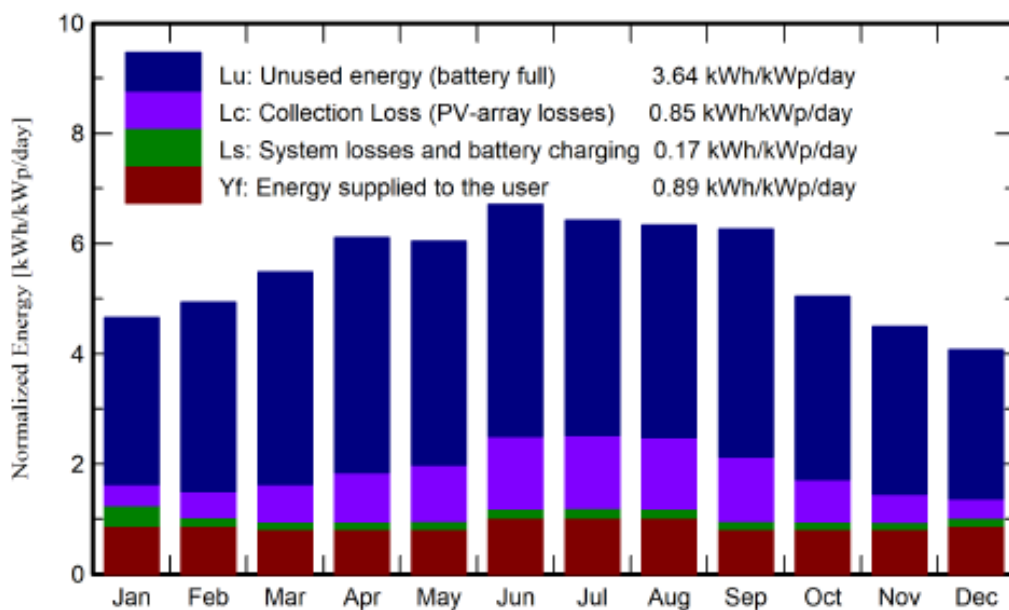

Figure 4. Normalized productions (per installed kWp)

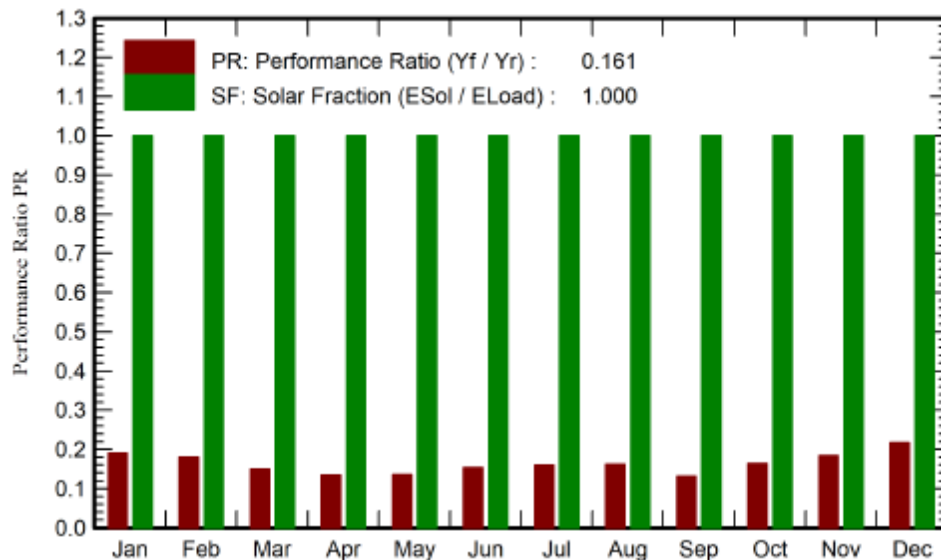

Figure 5. Performance ratio PR

## 5. Conclusion

The PV simulation system was applied in installing a solar cell on the roof of a house. Throughout the seasons of the year, the best location for the installation of the cell was determined, as the correct structure of the cell is essential in increasing the efficiency of the cell. As indicated by the data recorded during the research paper. This program was also applied to determine the effect of shadow on the cell and determine the optimal solution to avoid this effect on the efficiency of the cell in producing electrical energy.

## References

- [1] S. Gorjian, H. Sharon, H. Ebadi, K. Kant, F. B. Scavo, and G. M. Tina, "Recent technical advancements, economics and environmental impacts of floating photovoltaic solar energy conversion systems," *Journal of Cleaner Production*, vol. 278, p. 124285, 2021.
- [2] H. F. Khazaal, H. T. S. Alrikabi, F. T. Abed, and S. I. Kadhm, "Water desalination and purification using desalination units powered by solar panels," *Periodicals of Engineering and Natural Sciences*, vol. 7, no. 3, pp. 1373-1382, 2019.
- [3] M. Majhool, and H. Salim, "Design and Implementation of Sunlight Tracking Based on the Internet of Things," *IOP Conference Series: Earth and Environmental Science*, vol. 877, no. 012026, p. 11, 2021.
- [4] H. T. Salim, . M. S. Farhan, and M. H. Majhool, "Enhancing the Efficiency of Solar Cell Based on the Internet of Things Applications," *Wasit Journal Of Engineering Sciences*, vol. 10, no. 1, 2022.
- [5] Y. Yang, P. E. Campana, B. Stridh, and J. Yan, "Potential analysis of roof-mounted solar photovoltaics in Sweden," *Applied Energy*, vol. 279, p. 115786, 2020.
- [6] A. Z. Abass, Haider Th. ALRikabi, Faisal T. Abed, and Julian Gaidukov, "Economic Feasibility Study of a Hybrid Power Station Between Solar Panels and Wind Turbine with The National Grid in Al- Hayy City in the Central of Iraq," *IOP Conf. Series: Materials Science and Engineering*, vol. 1184, no. 012001, 2021.
- [7] H. T. Salim, and N. A. Jasim, "Design and Implementation of Smart City Applications Based on the Internet of Things," *International Journal of Interactive Mobile Technologies (iJIM)*, vol. 15, no. 13, pp. 4-15, 2021.
- [8] T. N. Sultan, M. S. Farhan, and H. T. S. ALRikabi, "Using Cooling System for Increasing the Efficiency of Solar Cell," in *Journal of Physics: Conference Series*, 2021, vol. 1973, no. 1, p. 012129: IOP Publishing.
- [9] R. M. Al\_ airaji, I. A. Aljazaery, S. K. Al\_ dulaimi, and H. T. S. Alrikabi, "Generation of high dynamic range for enhancing the panorama environment," *Bulletin of Electrical Engineering and Informatics*, Article vol. 10, no. 1, pp. 138-147, 2021.



- [10] F. T. Abed, and I. A. Ibrahim, "Efficient Energy of Smart Grid Education Models for Modern Electric Power System Engineering in Iraq," in *IOP Conference Series: Materials Science and Engineering*, 2020, vol. 870, no. 1, p. 012049: IOP Publishing.
- [11] F. Theyab, "Using IoT Applications for Detection and Monitoring of Underground Cable Fault," in *IOP Conference Series: Materials Science and Engineering*, 2021, vol. 1184, no. 1, p. 012003: IOP Publishing.
- [12] A. Z. Abass, and D. Pavlyuchenko, "The exploitation of western and southern deserts in Iraq for the production of solar energy," *International Journal of Electrical and Computer Engineering*, vol. 9, no. 6, p. 4617, 2019.
- [13] H. Tuama, H. Abbas, N. S. Alseelawi, and H. T. H. S. AlRikabi, "Bordering a set of energy criteria for the contributing in the transition level to sustainable energy in electrical Iraqi projects," *Periodicals of Engineering and Natural Sciences*, Article vol. 8, no. 1, pp. 516-525, 2020.
- [14] R. A. Azeez, M. K. Abdul-Hussein, M. S. Mahdi, and H. T. S. ALRikabi, "Design a system for an approved video copyright over cloud based on biometric iris and random walk generator using watermark technique," *Periodicals of Engineering Natural Sciences*, vol. 10, no. 1, pp. 178-187, 202
- [15] M. Valizadeh , H. Salim ALRikabi, and I. Alrubei, "Enhancing the efficiency of photovoltaic power system by submerging it in the rivers," *Telkonnika (Telecommunication Computing Electronics and Control)*, vol. 20, no. 1, pp. 166-172, 2022.
- [16] A. Z. Abass, D. Pavlyuchenko, Z. S. Hussain, and Control, "Survey about impact voltage instability and transient stability for a power system with an integrated solar combined cycle plant in Iraq by using ETAP," *Journal of Robotics*, vol. 2, no. 3, pp. 134-139, 2021.
- [17] I. M. Maclean, "Predicting future climate at high spatial and temporal resolution," *Global change biology*, vol. 26, no. 2, pp. 1003-1011, 2020.
- [18] O. Amrani and D. Rekioua, "Etude et identification des différents modèles Electriques photovoltaïques," in *International conference ICEA*, 2006, vol. 6.
- [19] B. Parida, S. Iniyar, and R. Goic, "A review of solar photovoltaic technologies," *Renewable sustainable energy reviews*, vol. 15, no. 3, pp. 1625-1636, 2011.
- [20] A. Mellit and S. A. Kalogirou, "Artificial intelligence techniques for photovoltaic applications: A review," *Progress in energy combustion science*, vol. 34, no. 5, pp. 574-632, 2008.
- [21] F. Adamo, F. Attivissimo, A. Di Nisio, and M. Spadavecchia, "Characterization and testing of a tool for photovoltaic panel modeling," *IEEE Transactions on Instrumentation Measurement*, vol. 60, no. 5, pp. 1613-1622, 2011.
- [22] A. Elkholly and A. Abou El-Ela, "Optimal parameters estimation and modelling of photovoltaic modules using analytical method," *Heliyon*, vol. 5, no. 7, p. e02137, 2019.
- [23] R. Kumar and S. Singh, "Solar photovoltaic modeling and simulation: As a renewable energy solution," *Energy Reports*, vol. 4, pp. 701-712, 2018.
- [24] S. Rustemli and F. Dincer, "Modeling of photovoltaic panel and examining effects of temperature in Matlab/Simulink," *Elektronika ir Elektrotechnika*, vol. 109, no. 3, pp. 35-40, 2011.
- [25] A. Mohammedi, D. Rekioua, and N. Mezzai, "Experimental study of a PV water pumping system," *Journal of Electrical Systems*, vol. 9, no. 2, pp. 212-222, 2013.
- [26] S. A. Rahman, R. K. Varma, and T. Vanderheide, "Generalised model of a photovoltaic panel," *Renewable Power Generation*, vol. 8, no. 3, pp. 217-229, 2014.
- [27] H. Yatimi and E. H. Aroudam, "A detailed study and modeling of photovoltaic module under real climatic conditions," *International Journal of Electronics Electrical Engineering*, vol. 3, no. 3, pp. 171-176, 2015.
- [28] N. Yildiran and E. Tacer, "Identification of photovoltaic cell single diode discrete model parameters based on datasheet values," *Solar Energy*, vol. 127, pp. 175-183, 2016.
- [29] R. Venkateswari and S. Sreejith, "Factors influencing the efficiency of photovoltaic system," *Renewable Sustainable Energy Reviews*, vol. 101, pp. 376-394, 2019.
- [30] H. Salim, and M. S. Farham "Investigation The Factors Affecting on The Performance of PV System," in *AIP conference proceedings*, 2021, vol. 2394, no. SICPS2021: AIP Publishing LLC.
- [31] M. Farhan, and D. Hasan, "Impact of Temperature and Dust Deposition on PV Panel Performance," in *AIP conference proceedings*, 2021, vol. 2394, no. SICPS2021: AIP Publishing LLC.
- [32] N. Mendalek and K. Al-Haddad, "Photovoltaic system modeling and simulation," in *2017 IEEE International Conference on Industrial Technology (ICIT)*, 2017, pp. 1522-1527: IEEE.



- [33] K. Ding, X. Bian, H. Liu, and T. Peng, "A MATLAB-simulink-based PV module model and its application under conditions of nonuniform irradiance," *IEEE Transactions on Energy Conversion*, vol. 27, no. 4, pp. 864-872, 2012.
- [34] K. Ishaque and Z. Salam, "A comprehensive MATLAB Simulink PV system simulator with partial shading capability based on two-diode model," *Solar energy*, vol. 85, no. 9, pp. 2217-2227, 2011.
- [35] S. R. Pendem and S. Mikkili, "Modeling, simulation and performance analysis of solar PV array configurations (Series, Series-Parallel and Honey-Comb) to extract maximum power under Partial Shading Conditions," *Energy Reports*, vol. 4, pp. 274-287, 2018.
- [36] M. H. Majhool, H. T. S. Alrikabi, and M. S. Farhan, "Using Internet of Things application for Monitoring Photo-Voltaic Panel Based on Ask Sensors Cloud," *Design Engineering*, pp. 3884-3896, 2021.
- [37] H. Alrikabi, A. H. Alaidi, and K. Nasser, "The Application of Wireless Communication in IOT for Saving Electrical Energy," *International Journal of Interactive Mobile Technologies*, vol. 14, no. 01, pp. 152-160, 2020.
- [38] S. Sindhu, "Assessment, simulation and analysis of PV power generation for educational buildings of a rural women's university in India: a case study," *International Journal of Energy Technology Policy*, vol. 17, no. 1, pp. 61-85, 2021.
- [39] L. Fara and D. Craciunescu, "Output analysis of standalone PV systems: modeling, simulation and control," *Energy Procedia*, vol. 112, pp. 595-605, 2017.
- [40] P. I. Barton and C. K. Lee, "Modeling, simulation, sensitivity analysis, and optimization of hybrid systems," *ACM Transactions on Modeling Computer Simulation*, vol. 12, no. 4, pp. 256-289, 2002.
- [41] J. Allegrini, K. Orehounig, G. Mavromatidis, F. Ruesch, V. Dorer, and R. Evins, "A review of modelling approaches and tools for the simulation of district-scale energy systems," *Renewable Sustainable Energy Reviews*, vol. 52, pp. 1391-1404, 2015.
- [42] A. Kavousian, R. Rajagopal, and M. Fischer, "Determinants of residential electricity consumption: Using smart meter data to examine the effect of climate, building characteristics, appliance stock, and occupants' behavior," *Energy*, vol. 55, pp. 184-194, 2013.
- [43] G. Tayfur, *Soft computing in water resources engineering: Artificial neural networks, fuzzy logic and genetic algorithms*. WIT Press, 2014.
- [44] P. Vas, *Artificial-intelligence-based electrical machines and drives: application of fuzzy, neural, fuzzy-neural, and genetic-algorithm-based techniques*. Oxford university press, 1999.
- [45] Y. S. Mezaal and S. F. Abdulkareem, "Affine cipher cryptanalysis using genetic algorithms," *JP J. Algebra Number Theory Appl.*, vol. 39, no. 5, pp. 785-802, 2017.
- [46] Y. S. Mezaal and H. T. Eyyuboglu, "Investigation of new microstrip bandpass filter based on patch resonator with geometrical fractal slot," *PLoS One*, vol. 11, no. 4, p. e0152615, 2016.
- [47] Y. S. Mezaal, H. T. Eyyuboglu, and J. K. Ali, "Wide Bandpass and Narrow Bandstop Microstrip Filters based on Hilbert fractal geometry: design and simulation results," *PLoS One*, vol. 9, no. 12, p. e115412, 2014.
- [48] Y. S. Mezaal and A. S. Al-Zayed, "Design of microstrip bandpass filters based on stair-step patch resonator," *Int. J. Electron.*, vol. 106, no. 3, pp. 477-490, 2019.
- [49] S. A. Shandal, Y. S. Mezaal, M. F. Mosleh, and M. A. Kadim, "Miniaturized wideband microstrip antenna for recent wireless applications," *Adv. electromagn.*, vol. 7, no. 5, pp. 7-13, 2018.