

Microstrip diplexer for recent wireless communities

Kadhun Al-Majdi,¹ Yaqeen Sabah Mezaal²

¹Ashur University College, Baghdad, Iraq

²Al-Esraa University College, Baghdad, Iraq

ABSTRACT

The diplexer is a dual-filter circuit with three ports that may share an antenna across two different frequency channels. As long as each band can be employed for sending and receiving signals, this technology can be used for multiple transmitters running on various frequencies. This paper will first present an overview of the diplexer concept, its importance in wireless networks, and its difference with duplexers. Then, the microstrip transmission line and its variation are discussed, as the filters and diplexers are designed using transmission lines. Typical electrical specifications are presented with measurement methods as well.

Keywords: Diplexer, filters, frequency bands, wireless systems

Corresponding Author:

Yaqeen Sabah Mezaal
Medical Instrumentation Engineering Department
Al-Esraa University College, Baghdad, Iraq
E-mail: yaqeen@esraa.edu.iq

1. Introduction

The multiplexers stand for critical constituents in communication systems such as cellular networks, radio transmissions, broadband wireless communications, and satellite-based systems. Networks with multiple ports employ them to segregate or mix signals of different frequencies [1]. The diplexer is the most straightforward kind of multiplexer. Rather than sending signals from two separate ports, it combines them into one. For example, a diplexer allows two transmitters (each on a separate frequency) to share an antenna. As a result, they are also helpful in forming the forms of duplexers, which allow a receiver and a transmitter operating on different frequencies to share one common antenna with a lower level of interference between the signals. It is, therefore, possible to reduce the weight and volume of a device by using a single antenna [2]. High- and lowpass filters can also be employed as bandpass filters to achieve diplexer. All signals below the cutoff frequency of the lowpass filter are routed to the first channel, while all signals above the cutoff frequency of the highpass filter are sent to the second channel. Highpass and lowpass filters do not have a direct path; therefore, signals can pass through the highpass but not the lowpass [3], as in Figure 1.

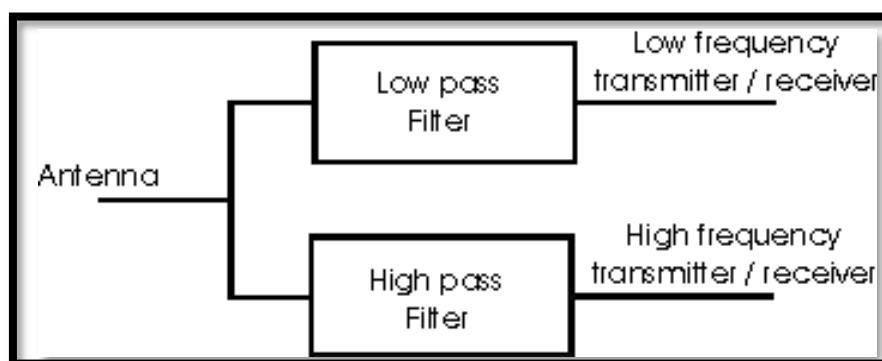
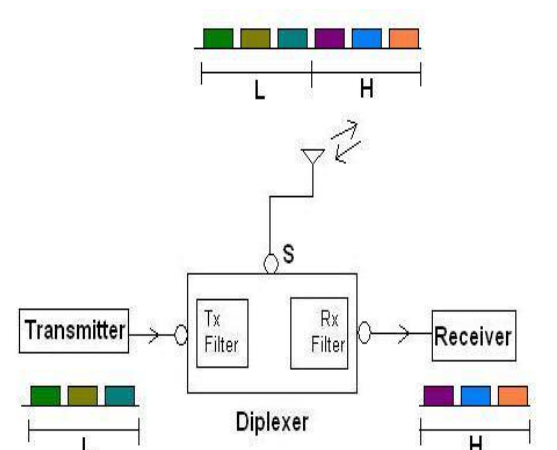
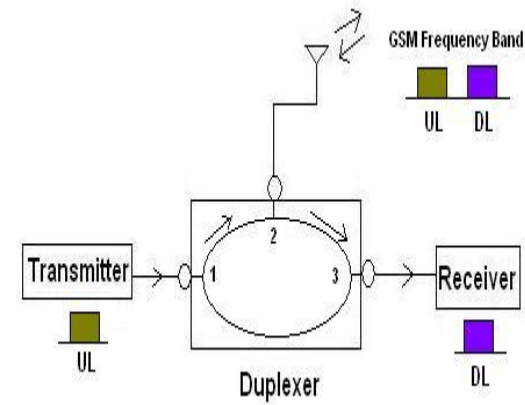

Figure 1. The depiction of low/highpass filter diplexer [3]

2. The differences between diplexer and duplexer

Table 1 illustrates the differences between a diplexer and a duplexer. A diplexer can communicate in both directions using a single antenna when used as a duplexer. There is a shared port on the diplexer where signals are sent in opposite directions [2, 4].

Table 1. The differences between diplexer and duplexer

| Diplexer | Duplexer |
|--|---|
| <p>1) Diplexer is a device that can combine and separate two different frequency bands in transmit and receive paths.</p> <p>2) Receive and transmit paths will be wide apart in the frequency band.</p> <p>3) It is referred to as an RF power separator or combiner with added functions of filter [4].</p>  | <p>1) Duplexer is a device that could use one antenna for both receiver and transmitter.</p> <p>2) Receive and transmit paths will possess very nearer frequency bands.</p> <p>3) Duplexer is a three-port RF circulator [4].</p>  |

3. The standards of wireless systems

They are computer network that uses a wireless distribution mechanism to connect two or more devices in a confined area, such as a home, office building, or university. This type of network is known as a Wireless Local Area Network. To use this, users must be located inside a specific coverage area. Known as "Wi-Fi," today's WLANs are based on IEEE 802.11 standards developed by the Institute of Electrical and Electronics Engineers. Wireless local area network (WLAN) communication in the 5, 3.6, 2.4, and 60 GHz frequency bands are enabled by IEEE 802.11's Physical Layer (PHY) and Media Access Control (MAC) protocols. IEEE 802 is responsible for their development and upkeep. The first version of the standard, introduced in 1997, has undergone numerous revisions since then.

Each half-duplex through-the-air modulation technology within the IEEE 802.11 family uses the same protocol. Even though IEEE 802.11-1997 was the initial standard in the family, it wasn't until 802.11 b that it gained widespread acceptance. An illustration of the IEEE 802.11 standard family can be found in Table 2 [5, 6].

Table 2. The family of IEEE 802.11 standards

| IEEE 802.11 | Frequency | Maximum speed | Background compatible |
|-------------|-----------|---------------|-----------------------|
| 802.11a | 5 GHz | 54 Mbps | No |
| 802.11b | 2.4 GHz | 11 Mbps | No |
| 802.11g | 2.4 GHz | 54 Mbps | 802.11 b |

| IEEE 802.11 | Frequency | Maximum speed | Background compatible |
|-------------|----------------|---------------|-----------------------|
| 802.11n | 2.4 GHz, 5 GHz | 600 Mbps | 802.11 a/b/g |
| 802.11ac | 5 GHz | 1.3 Gbps | 802.11 b/g/n |

4. Microstrip filter and diplexer design basics

4.1. Microstrip line structure

The microstrip layout is depicted in Figure 2. There is a conducting strip on the top of a dielectric substrate with a thickness (t) and a width (W) and a ground (conducting) plane on the bottom of it [7]. The dielectric constant is symbolized by ϵ_r , and its thickness is denoted by h .

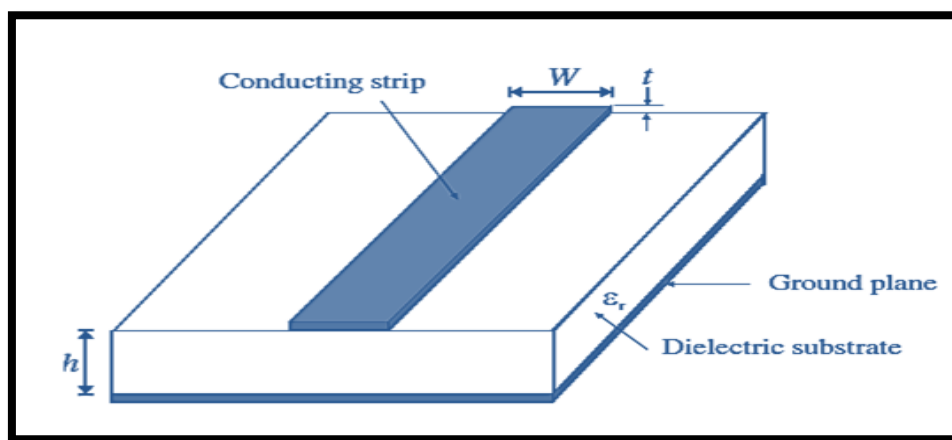

Figure 2. Microstrip structure

There must be an even distribution of lumped elements, as in Figure 3, such as resistance (R), shunt conductance (G), inductance (L), and capacitance (C), along the entire transmission line's length [8].

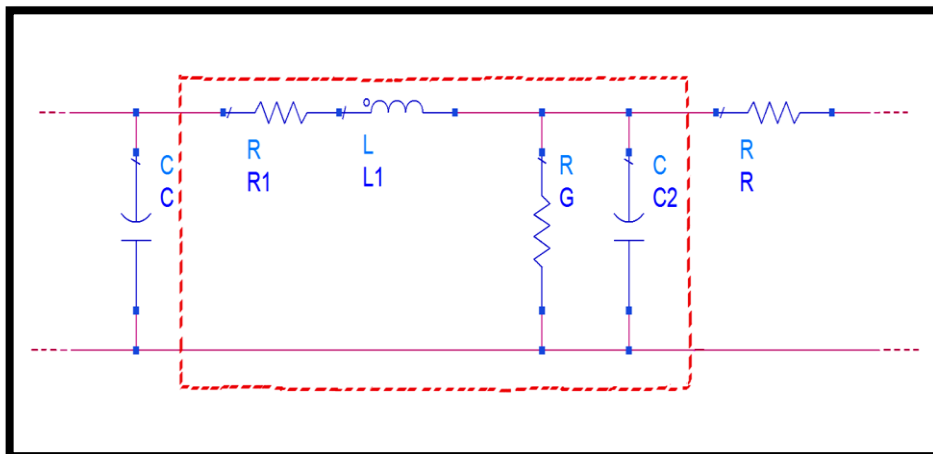

Figure 3. C, L, R, and G are transmission line elements

4.2. Microstrip resonators

Using lumped (such as capacitors and inductors) or quasi-lumped (such as stubs and short line portions) microstrip components in a filter design are possible. Distributed elements such as half-wavelength and quarter-wavelength line resonators are used in most applications. Selecting the right filter is critical for choosing an

appropriate component type, quality factors (acceptable losses), fabrication procedures, frequencies of operation, and power handling [7].

Depending on the design, microstrip resonators can be lumped, quasi-lumped, patch, or distributed-line resonators.

It is possible to build resonators with lumped or quasi-lumped capacitors and inductors that are both quasi-lumped and lumped. These elements are ineffective at higher frequencies. Microstrip structures may be made from equivalent circuits that automatically use inductors and capacitors, which is advantageous [7, 8, 9].

The term "distributed resonators" refers to resonators in which the magnetic and electric fields are dispersed across the resonant structure. The simplest distributed microstrip resonator [8] is a microstrip line section.

Resonators with a quarter-wavelength distributed line are called a quarter-wavelength distributed line (where λ_{g0} is the guided wavelength at the fundamental resonant frequency f_0). An open-circuit or short-circuit version of this device can be used in place of this resonator (equivalent to a series LC resonator). Microstrip filters can also be implemented using a resonator known as the $\lambda_{g0}/2$ resonator. The main drawbacks of using dispersed line resonators are conductor loss, dielectric dissipation loss, and radiation losses [10].

The ring resonator is another type of distributed line resonator. The resonator is generated at a specific frequency range in a straightforward transmission line. The circular path of the resonator can form a standing wave pattern based on the electrical length at resonant frequency [10-11].

With lower conductor losses and higher power handling capacity than traditional microstrip line resonators, patch resonators have become very popular in microstrip filter design. Depending on the application, patch resonators can be triangular or circular [7]. Figure 4 depicts an example of each of these.

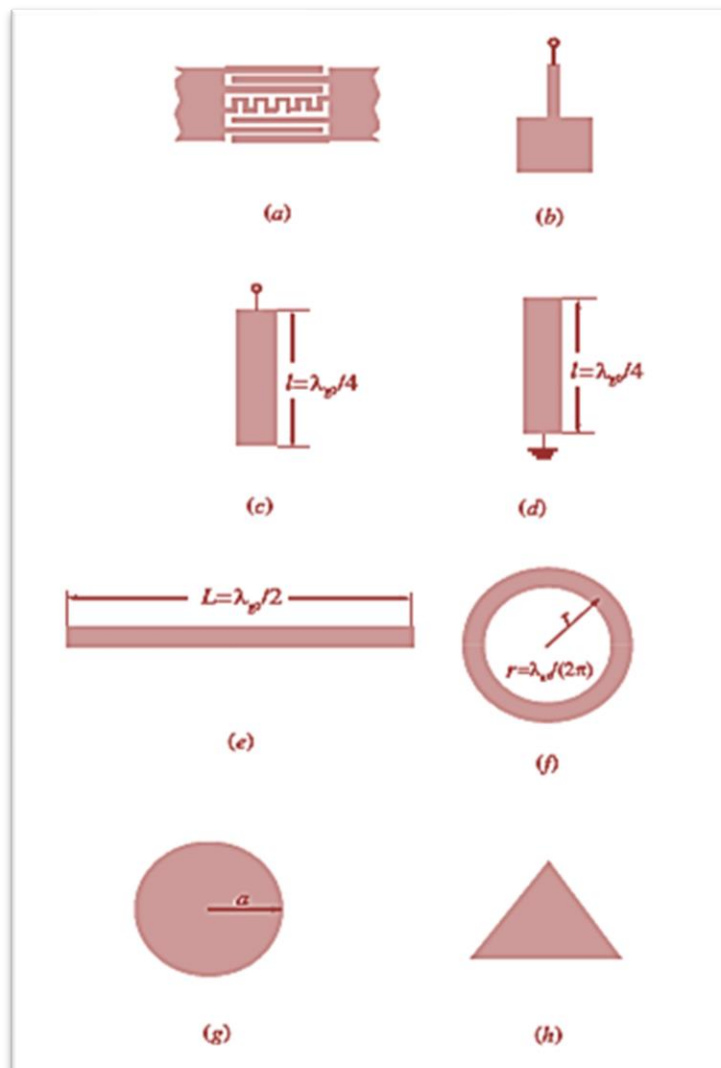

Figure 4. Several structures for microstrip resonators

4.3. Transmission line resonator and SIR

Transverse Electromagnetic Mode (TEM) mode transmission line resonators include coaxial, strip, and microstrip resonators.

Uniform Impedance Resonator resonators are used in transmission lines (UIR). The dielectric substrate material must have a high permittivity, a low loss tangent, and temperature stabilization as the minimum requirements for UIR. The UIRs are widely utilized in design because of their basic form and ease of use.

Other electrical limitations include spurious responses at integer multiples of the critical frequency. These problems can be avoided by adding capacitance loads on the open terminals of the resonator, even though their structure is simple. At extremely high frequencies, it is a common practice. There are fewer spurious frequencies to deal with, and they're shifted from multiple integers of the fundamental frequency [7, 10, 12].

A structure difference of $\lambda_{g0}/2$ resonator is depicted in Figure 5. The capacitor-loaded UIR here has an electrical length of $2\theta_1$ and a characteristic impedance of Z_1 . As ω_0 (radian resonant frequency) for this resonator is based on half-wavelength UIR illustrated in Figure 5 (a), a loading capacitance is feasibly determined by [7, 13]:

$$C = Y_1 \tan \theta_2 / \omega_0 \quad \dots(1)$$

$$\text{Where } \theta_2 = \pi/4 - \theta_1, Y_1 = 1/Z_1 \quad \dots(2)$$

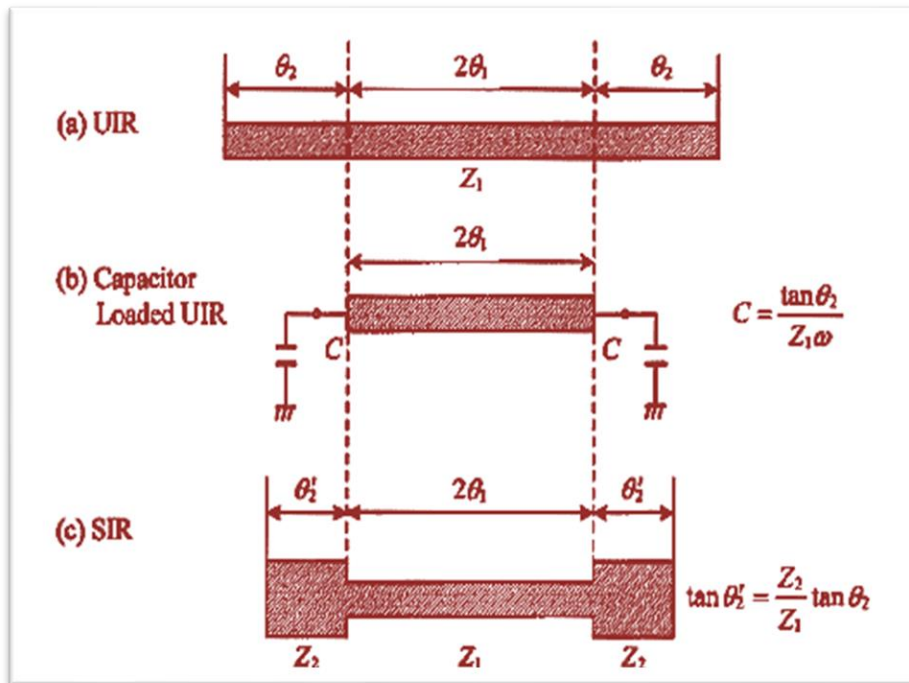

Figure 5. Structure variation a half-wavelength resonator. (a) UIR. (b) Capacitor loaded UIR. (c) SIR.

Based on Figure 5 (a), the transmission line constituents with electrical lengths of θ_2 are substituted with capacitors as in Figure 5 (b). A capacitor-loaded UIR can exclude spurious response, and it has a reasonably compact size.

Capacitor loss in the lumped-element capacitance rises noticeably as the resonant frequency increases around 1 GHz, making it difficult to stratify the capacitance-loaded UIR. As a result, frequency tinkering is required here.

An open-circuit transmission line can replace the capacitance that is being loaded. Furthermore, the characteristic impedance of a transmission line does not necessarily need to be designed at Z_1 . Figure 5 (c) explains a characteristic impedance designed at $Z_2 = (1/Y_2)$. When $Y_2 \tan \theta_2 = Y_1 \tan \theta_2$. All constituents can be resonant at an identical frequency. In view of that, if Z_2 is less than Z_1 , then $\theta_2 < \theta_1$. As a result, the resonator's length can be reduced. Capacitors are removed from UIR's design to display other features, such as a tiny difference in resonance frequency and low-loss properties. Using a capacitance-loaded technique, this device overcomes the previously exhibited weaknesses Figure 5 (b).

There are considerable differences in characteristic impedance between SIRs depicted in Figure 5 c [7].

4.4. SIR structure

Dual or more variable characteristic impedances are presented in Figure 6 for SIR, a TEM or quasi-TEM component. Examples of its structural differences in the stripline arrangement are depicted in this diagram, where Figure 6 (a, b, c) respectively are instances of $\lambda_g/4$, $\lambda_g/2$, and λ_g -type resonators. Another transmission-line structure other than the exemplified stripline outline, like coplanar and coaxial-line, are tolerable based on TEM /semi-TEM mode resonance condition. As the $\lambda_g/2$ -type SIR, as in Figure 6 (b), uses an open-ended structure, short-circuited structures have been correspondingly obtainable [7, 14].

Z_1 and Z_2 denote characteristic impedances for SIR constituents, and θ_1 and θ_2 indicate electrical lengths of transmission lines amid the short-and open-circuited ends, as depicted in Figure 6.

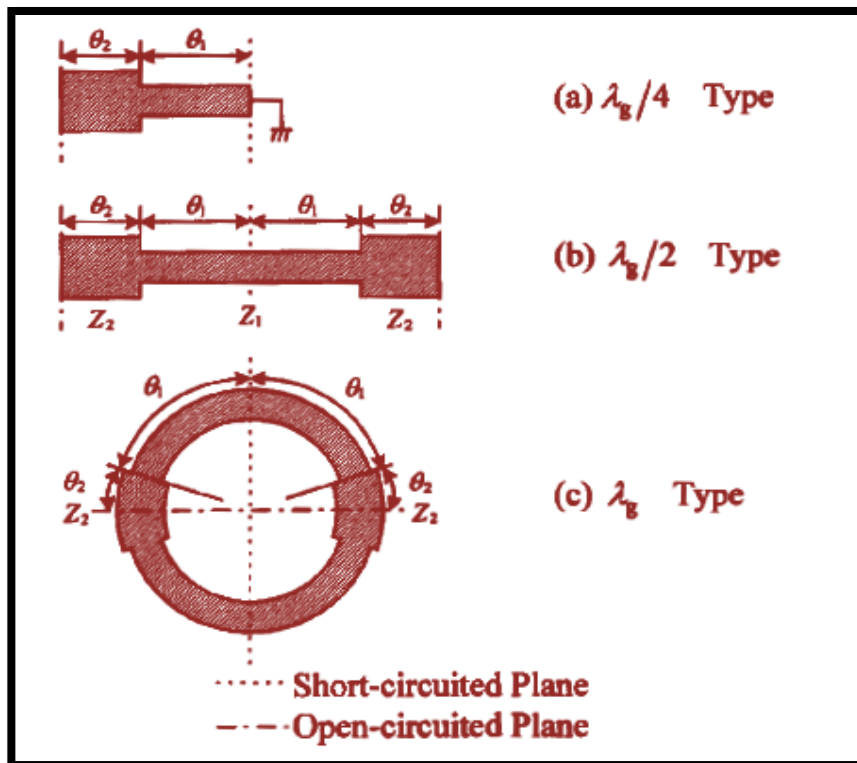

Figure 6. A structure for basic SIR. (a) 1/4 wavelength($\lambda_g/4$). (b) 1/2 wavelength($\lambda_g/2$). (c) Unitary wavelength (λ_g).

The significant parameter in describing the properties of SIR is signified by R_z , which is the transmission line impedances Z_2 and Z_1 ratio as follows [7, 14]:

$$R_z = Z_2/Z_1 \quad \dots(3)$$

More details and mathematical equations about SIR and its varieties are reported in [7, 12, 14].

5. Literature survey

There have been prior examinations of the feasibility, viability, and cost-effectiveness of filters and diplexers. This effort is a continuation of those investigations to find the best possible solutions. Such measures must be examined to avoid the technical problems that can arise from work evolving so quickly. In the following section, a chronology of published material is reviewed to cover the many stages of development of these activities.

Using small hybrid resonators, Yang et al. 2010 [15] reported a microstrip diplexer with sound isolation that is compact and efficient. Its operating frequencies are 1.8 GHz and 2.45 GHz, with more than 55 dB band isolation. An independent, reconfigurable dual-band filter with sound isolation between the two bands was presented by Deng and Jheng in 2011 [16]. It is possible to isolate two mid-band frequencies at 1.5 GHz and 2 GHz with more than 37 dB.

By using branch-line resonators with output and input ports closer together, Deng and Tung (2011) [17] suggested a novel dual passband filter type. Because each passband response of the proposed filter structure may be individually designed, the coupling coefficients can be derived separately.

Distributed coupling feeding lines, uniform resonator pairs, and output feeding lines were used in a microstrip quadruplexer with sound isolation by Zeng et al. 2011 [18]. Flexibility is achieved by controlling each channel's frequency separately, and the loading impact between channels is relatively low in the suggested system.

A four-band microstrip bandpass filter was suggested by Wu and Yang in 2011 [19] using stepped impedance resonators. 1st and 2nd passbands (2.4 and 3.5 GHz) are used along with the 3rd and 4th passbands (5.2 and 6.8 GHz) with minimal insertion loss and compact dimensions.

Resonators with uniform impedance and stub-loaded stepwise impedance were used in a multi-layered dual-band BPF system by Wu et al. [20]. 2.4 and 5.2 GHz were the frequencies of the dual-passband. The filter's performance and small size were boosted based on multi-path propagation.

An isolated microstrip triplexer was presented by Wu et al. in 2012 [21]. There was no increase in circuit size as a result of this. Distribution coupling is used to convert the diplexer into a triplexer by adding a third channel. Using a simple matching circuit, Deng and Tsi 2013 [22] developed a new lowpass-bandpass diplexer. The simulated cutoff frequency for the lowpass channel is 1.5 GHz. The simulated 2.4 GHz center frequency is in the bandpass channel with 35 dB of separation between the bands.

Wu et al. 2013 [23] demonstrated a compact quad-channel diplexer working at (1.5/ 2 GHz, 2.4/ 3.5 GHz) using a connected pair of diplexers based on stepped impedance resonators. The quad-channel diplexer has a simple configuration, sound S parameters, and compact size.

A short-ended stepped impedance dual resonator was proposed by Sun et al. in 2013 [24]. 4.2 GHz appears to be the initial spurious frequency in the first design. Dual/tri-band BPFs are the second design. Passbands are produced and measured for three filters with one, two, and three passbands, respectively

Short-and open-ended stub-loaded, stepped impedance resonators were used in a six-band triplexer by Zhang et al. 2014 [25]. A T-shaped SIR feed line is used to connect three separate dual-band channels. Triplexes working at (1.9/2.4, 3.5/4.2, and 5.2/5.8 GHz) in a compact size with sound isolation and minimal insertion loss have been developed.

In [26], using microstrip open-loop coupled resonators, a dual-channel diplexer has been built and simulated; each channel has two operating frequency bands. Microstrip diplexer is intended for the first channel (1.424/1.732 GHz) and the second channel (2.014/2.318 GHz). Insertion loss at load 1 is (1.8 and 1 dB), and at load 2, it is (1.5 and 3 dB). The isolation between channels is effective at 35 dB, and the return loss is within a reasonable range. The suggested design is well-suited for use in multiple wireless service scenarios with a simple topology, efficient design, compact circuits, and narrowband frequency responses.

Fractal geometries are as well feasible to design diplexer. For instance, in [27], a small microwave diplexer was created by exploiting fractal geometry to form transmission lines with composite left-handed and right-handed properties. Nevertheless, fractals have more complicated formulas and iterations than SIR, UIR and Euclidean topologies.

The tiny microstrip diplexer based on FR4 substrate material has been constructed for dual channels [28]. An integrated circuit comprises two bandpass filters (BPFs) operating in different frequency ranges. As a result of a combination of input/output feed lines and a meandering line, SIR, and UIR, each BPF has been developed. The diplexer's frequency response has been characterized using the AWR electromagnetic simulator. The proposed diplexer has noble scattering results in terms of narrowband responses and negative group delays with band isolation of 31 dB.

6. Desired specifications of diplexers and measurement

The terminal attenuation caused by the insertion of a device into the signal channel is usually addressed using insertion loss, which is measured in decibels (dB). While return loss is a measurement of the voltage standing wave ratio, it is a different kind of measurement that is measured in decibels (dB) as well. It is a result of circuit impedance differences. Additionally, material qualities and cable size significantly affect impedance match and mismatch constraints at frequencies above 1 GHz: the bigger the return loss magnitude, the better the system being tested.

Typically, for diplexers, the insertion loss is preferred to be better than 1 dB, while return loss must be higher than 10 dB in simulations and measurement. Band isolation is desired to be better than 20 dB.

Microwave devices are best measured with vector network analyzers (VNAs), as in Figure 7. Filters and diplexers are just a few examples of RF and microwave devices that can be found in everything from satellites to medical equipment. VNAs are the most complex and diverse test instruments. A VNA, which contains both

a source and a network of receivers, can detect changes in the known stimulus signal from the device under test (DUT).

Signals from the input and output are measured using VNA in conjunction with each other. Results are compared to the stimulus signal using VNA receivers. After that, the measured data is processed and sent to a display, either by an internal or external PC.

VNAs can provide a wide range of accurate measurements of any RF sensor. Poor quality or broken testing port cables significantly degrade the accuracy of VNA measurements, thereby exacerbating measurement mistakes. VNA's sound quality will be limited by the quality of the test port cables, just like if you connected a high-end audio receiver to cheap speakers. Even if you use the most accurate VNA in the world and low-quality cables to connect to the DUT, your measurement results are likely to be erroneous with DUT.



Figure 7. VNA measuring device

Several RF and microwave devices can be investigated using the NanoVNA (S-A-A-V2), as shown in Figure 8, including filters and diplexers. NanoVNA is a mini portable VNA that can yield scattering characteristics, phase responses, and even smith charts with nonlinear features throughout a frequency range of 50 kHz to 4.4 GHz. In a nonlinear connection, changes in input frequency have no direct correlation to changes in the scattering responses. NanoVNA is a good choice for microwave engineers and amateurs, although it has limited sweeping frequencies.



Figure 8. NanoVNA (S-A-A-V2)

7. Conclusion and recommendation

A diplexer represents two filter components having three ports that enables two distinct frequency bands to share an antenna. This device enables transmitters running at various frequencies to share one antenna, with each band capable of transmitting and/or receiving. Using SIR along with UIR as a design tool for diplexer configurations gives us all the advantages of fractal filters but with a lot less complexity in terms of simulation and fabrication. In addition, they are small enough to fit into wireless and mm-wave transceivers since compactness with tolerable frequency responses is highly requested by microwave engineers.

Diplexers can be utilized for biomedical applications to manage medical signals based on the dedicated band on each channel. To resolve the problems of loss tangent for FR4 substrates, Kappa substrate can be used in diplexer, triplexer, and even quadriplexer for modern wireless applications since it has a very low loss tangent value. Nano-Diplexers are as well must be investigated and studied thoroughly as future trends.

References

- [1] R. J. Cameron, C. M. Kudsia, and R. R. Mansour, *Microwave filters for communication systems: Fundamentals, design, and applications*, 2nd ed. Nashville, TN: John Wiley & Sons, 2018.
- [2] Y. S. Mezaal and S. K. Khaleel, "Mathematical Analysis of Microstrip Diplexer Design for WLAN System," *Int. J. Eng. Technol.*, vol. 7, no. 4.36, p. 1208, 2018.
- [3] <http://www.radio-electronics.com/info/antennas/diplexer/antenna-rf-diplexer.php>, "Antenna Diplexer-Radio-Electronics", Online, 2022.
- [4] <https://www.rfwireless-world.com/Terminology/diplexer-versus-duplexer.html>, "Diplexer Duplexer-RF Wireless Word", Online, 2022.
- [5] https://en.wikipedia.org/wiki/Wireless_LAN, "Wireless LAN-Wikipedia, the Free Encyclopedia", Online, 2022.
- [6] https://en.wikipedia.org/wiki/IEEE_802.11, "IEEE 802.11-Wikipedia, the Free Encyclopedia", Online, 2022.
- [7] J. S. Hong and M. J. Lancaster, "Microstrip Filters for RF/Microwave Applications", John Wiley & Sons, Inc., 2001.
- [8] M. Krawczyk, "Microstrip Resonators for Circuit Quantum Electrodynamics", M.Sc. Thesis, Technische Universität München, 2011.
- [9] M. Reppel, "Novel Hits Microstrip Resonator Configurations for Microwave Bandpass Filters", Ph.D. Thesis, Bergische Universitaet, 2000.
- [10] D. M. Pozar, "Microwave Engineering", John Wiley & Sons, Inc., 2012.
- [11] I. Rosu, "Microstrip, Stripline, and CPW Design", YO3DAC / VA3IUL, 2012.
- [12] Mezaal, Yaqeen S., Halil T. Eyyuboğlu, and Jawad K. Ali. "New microstrip bandpass filter designs based on stepped impedance Hilbert fractal resonators." *IETE Journal of Research* 60, no. 3 (2014): 257-264.
- [13] M. Makimoto and S. Yamashita, "Microwave Resonators and Filters for Wireless Communication System", Spring, 2000.
- [14] Y. S. Mezaal, "New printed slot antennas with etched SIR components in the ground plane," *J. Electromagn. Waves Appl.*, vol. 36, no. 3, pp. 388–406, 2022.
- [15] T. Yang, P.L. Chi, and T. Itoh, "High Isolation and Compact Diplexer Using the Hybrid Resonators", *IEEE Microwave Wireless Component Letter*, Vol. 20, No. 10, pp. 551–553, 2010.
- [16] P. H. Deng and J. H. Jheng, "A Switched Reconfigurable High-Isolation Dual-band Bandpass Filter", *IEEE Microwave Wireless Component Letter*, Vol. 21, No. 2, pp. 71–73, 2011.
- [17] P. H. Deng and H. H. Tung, "Design of Microstrip Dual-passband Filter Based on Branch-line Resonators", *IEEE Microwave Wireless Component Letter*, Vol. 21, No. 4, pp. 200–202, 2011.
- [18] H. W. Wu and R. Y. Yang, "A New Quad-band Bandpass Filter Using Asymmetric Stepped Impedance Resonators", *IEEE Microwave Wireless Component Letter*, Vol. 21, No. 4, pp. 203–205, 2011.
- [19] S. J. Zeng, J. Y. Wu, and W. H. Tu, "Compact and High-Isolation Quadriplexer Using Distributed Coupling Technique", *IEEE Microwave Wireless Component Letter*, pp. 197–199, 2011.
- [20] H. W. Wu, Y. F. Chen and Y. W. Chen, "Multi-layered Dual-band Bandpass Filter Using Stub-loaded Stepped-impedance and Uniform-impedance Resonators", *IEEE Microwave Wireless Component Letter*, Vol. 22, No. 3, pp. 114–116, 2012.

- [21] J. Y. Wu, K. W. Hsu, Y. H. Tseng, and W. H. Tu, "High-isolation Microstrip Triplexer Using Multiple-mode Resonators", *IEEE Microwave Wireless Component Letter*, 22, (4), pp. 173–175, 2012.
- [22] P. H. Deng and J. T. Tsai, "Design of Microstrip Lowpass-Bandpass Diplexer", *IEEE Microwave Wireless Component Letter*, Vol. 23, No. 7, 2013.
- [23] H. W. Wu, S. H. Huang, and Y. F. Chen, "Design of New Quadchannel Diplexer with Compact Circuit Size", *IEEE Microwave Wireless Component Letter*, 23, (5), pp. 240–242, 2013.
- [24] S. J. Sun, T. Su, K. Deng, B. Wu and C. H. Liang, "Shorted-ended Stepped-impedance Dual-resonance Resonator and its Application to Bandpass Filters", *IEEE Trans. Microwave Theory Tech.*, 61, (9), pp. 3209–3215, 2013.
- [25] L. Z. Zhang, B. Wu and F. Qiu, "Compact Six-band Triplexer Using Stub-loaded Stepped Impedance Resonators" *Electronics Letters*, Vol. 50 No. 16, pp. 1143–1145, 2014.
- [26] Y. S. Mezaal, S. A. Hashim, A. H. Al-fatlawi, and H. A. Hussein, "New microstrip diplexer for recent wireless applications," *Int. j. eng. Technol.*, vol. 7, no. 3.4, p. 96, 2018.
- [27] H.-X. Xu, G.-M. Wang, and H.-P. An. "Hilbert fractal curves form compact diplexer." *Semiconductors*, 2020.
- [28] H. A. Hussein, Y. S. Mezaal, and B. M. Alameri, "Miniaturized microstrip diplexer based on FR4 substrate for wireless communications," *Elektron. ir elektrotech.*, 2021.