

Structural behavior of two-way slabs cast with different fiber types and contents

Mohammed Farhan Ojaimi¹, Malik K. Eb. Altaee², Nooralhuda Sami Aljabbri³

¹ Department of Civil Engineering, College of Engineering, Basrah University, Basra, Iraq

² Department of Reconstruction and Projects, Thi Qar University, Thi Qar, Iraq

³ Department of Civil Engineering, Iraq University College, Ashar, Basra, Iraq

ABSTRACT

This paper presents an experimental investigation on the effects of incorporating Stainless-Steel Fibers (SSF) on the flexural behavior of reinforced concrete two-way slabs. For this deal, three types of steel fiber (straight, hooked, and corrugated steel fiber) are used. Each type of steel fiber was added in four different volume fractions. Each steel fiber shape was added separately by proportions (0, 0.5, 1, 1.5) % of the total concrete volume. Subsequently, ten 800 × 800 mm × 100 reinforced concrete slabs (three slabs for each type of fibers, one for each proportion, and the remaining one slab was the control) were cast and subjected to flexural tests. The effect of type and amount of SSF on flexural behavior of two-way slabs were studied. That, where 0.5% of steel fibers was added, the straight fibers were acknowledged in comparison to the others whereas the improvement to the stiffness was better and the ultimate load increased by 22.58%. At 1% of steel fibers, the ultimate load increased by (35, 43, and 29) % for straight, hooked, and corrugated fibers respectively which at this addition ratio the hooked fibers were the notable contributor as opposed to other types, and this observation was apparent in improving splitting and flexure strength for hardened concrete. Adding 1.5% of steel fibers to the concrete degrade the workability severely by (83-92)% for all types of steel fibers in parallel with little improvement on slabs behavior is contrary to 1% ratio, thus, the 1% is the recommended addition.

Keywords: Two Way Slabs, Flexural Behavior, Stainless-Steel Fibers, Fibers Reinforced Concrete

Corresponding Author:

Mohammed Farhan Ojaimi
Civil engineering, Basrah University
Basrah, Iraq
mohammed.ojaimi@uobasrah.edu.iq

1. Introduction

Reinforced concrete is a widely used construction; thus, its properties request continuous improvement. Concrete has low tensile strength and cracking occurs at comparatively low loads. The addition of steel fiber plays an apparent title role in the improvement of the properties of concrete, including tensile properties, crack control, strength, and ductility. Since the 1900s steel fibers have been used in concrete industries Mohd and Ajay [1]. Characteristically, depending on the cross-sectional area, the diameter of steel fibers has an equivalent diameter of 0.15 mm to 2 mm and lengths from 7 to 75 mm. The aspect ratio ranges from 20 to 100. Based on their manufacture, ASTM A 820 [2] categorizes five types of steel fibers; smooth/deformed drawn cold wire, smooth/deformed cut-sheet, melt extracted fibers, mill cut, or improved drawn cold wire fibers that are appropriately small to be spread randomly in a concrete.

1.1 Related works

Mustafa et al (2021) [3] studied the effect of types of fibers on the shear behavior of deep beams with the opening. They noted that the concrete beams with steel fiber had improved the mechanical properties (compressive and tensile strengths, elastic modulus, and bending strengths) and shear resistance.

Hang et al (2020) [4], used twelve shear tests on fiber-reinforced pre-cast-prestressed concrete hollow-core slabs to investigate the effect of the fiber on shear strength. The results show that adding the fiber produces a substantial increase in shear resistance, most of the specimens failed in shear except in some cases the failure shifted from shear zone to flexure.

Esraa (2019) [5] studied the advantages of combining three materials steel-carbon-plastic on the behavior and strength of concrete beams. The results stated the combination was economical, improve the ultimate load.

Kaize Ma (2018) [6] found that the steel fibers facilitate the internal stress distribution after the first crack forms in the deep beam.

Nafisa et al., (2018) [7], concluded that both the compressive and flexural strengths of concrete increase with the presence of steel fiber. Also, the cracking and failure pattern of concrete beams specimens show better ductility compared to control concrete.

Sivakumar, (2018) [8], presented a study on high-strength concrete beams and the results showed that the steel fibers provide effective bonds and increase the concrete fracture strength.

Prabhu (2018) [9] studied the flexural behavior of fly ash reinforced concrete beams with steel fiber, whereby, replacing the cement with fly ash at 40%; the results showed an increase in the load capacity with the addition of steel fiber.

Muyasser Jomaa'h et all (2018) [10], replaced the normal reinforcing rebar with two types of fibers (usual fibers and recycled fibers, both are steel made) by 0.125%, 0.25%, and 0.375% replacement ratios. The outcomes showed a decrease in maximum failure load value and the resultant deflection in concrete slabs. Also, the study recommended a replacement ratio of 0.125% of the main rebar by steel fibers to obtain the best value of maximum load and deflection.

Joshua and Anna (2018) [11], searched for the improvement of the one-way slab strip performance by involving steel fibers with conventional rebar. They concluded that adding the steel fibers can reduce the required reinforcement. Also, applying the conclusions to a bridge deck found that it satisfies service performance necessities or makes a longer span without the need for further reinforcement.

Gediminas and Salna (2017) [12], studied fibers-reinforced concrete slabs whereby the effect of steel fibers on punching shear strength. They concluded that the strength, shape, and type of fibers affect the shear strength, especially in the punching zone.

David Fall et al, (2014) [13], investigated the load redistributions in steel fibers reinforced concrete two-way slabs, the results showed that the addition of steel fibers reinforcement increased the amount of load carried in the secondary direction. Also, it was concluded that the steel fibers increase the load-carrying capacity. Besides, the crack pattern was the same as the control slab, but, with steel fibers, additional cracks produced, narrower cracks.

Kandasamy, (2011) [14] showed that adding steel fibers partially reduces, up to appreciated limits, the brittleness of concrete, which is caused rapid and catastrophic failure, especially at the earthquake, blast, or sudden loads.

2. Experimental program

2.1 Materials

Ordinary Portland cement and natural coarse (gravel) and fine aggregate (sand) were used local materials. To evaluate the properties of materials, standard testing is carried out based on the American Society of Testing and Materials (ASTM), [15,16] and Iraqi specifications No.45/1984 [17]. All the tests were executed in the Structural Laboratories of the College of Engineering of the University of Basrah. Potable water was used for all the mixes since it is a normally accepted view that any potable water is appropriate to be utilized in concrete making. The high range water reducer (HRWR), Glenium 51, was used to produce higher

compressive strength for concrete. Ukrainian brand deformed steel reinforcing bars with a diameter of ($\text{\O}12\text{mm}$) was used which satisfy the (ASTM A615/ A615M-05) [18], Table 1.

Table 1. Rebar test results

Diameter (mm)	Yield Strength (f_y - MPa)	Ultimate Strength (f_u - MPa)	Modulus of Elasticity (E_s - GPa)
12	506	663	199.8

2.1.1 Steel Fibers

To examine the fibers shape effect on fresh, hardened concrete, and the flexural behavior of two-way slabs, three types of steel fiber was used in this scope. Each type of steel fiber is added in different volume fractions separately by proportions (0, 0.5, 1, 1.5) % of the total concrete volume. The aspect ratio for the fibers with a non-circular cross-section was obtained through the equivalent diameter. The aspect ratio is of importance as the fibers that are too long tend to sphere in the mix and affect the workability negatively. Also, some recent researchers indicated that the microfibers deliver better impact resistance for the concrete in comparison to longer steel fibers. The steel fibers are presented in detail in Figure 1 and Table 2.



Figure 1. Steel fibers shapes

Table 2. Steel fibers details

Shape	Length mm	Diameter mm	Aspect Ratio L / D	Tensile Strength MPa
Hooked	30	0.50	60.00	≥ 1000
Corrugated	30	0.55	55	≥ 700
Straight	12.5	0.25	50.00	≥ 2850

2.2 Concrete mix proportions

The mix was 1:1.8:3 (by weight) for the three components cement, sand, gravel respectively. The weights of them were reduced at each addition of fibers. While the 0.47 water-cement ratio and SP dosage were kept unchangeable. Table 3 shows the mix proportions of all concrete mixes of the study and how the other contents change depending on steel fiber content.

Table 3. All used mixes proportions

Material kg / m^3	Steel Fibers Volume			
	0	0.5%	1.0%	1.5%
Cement	402	399.99	397.98	395.97
Sand	723.50	719.88	716.26	712.64
Gravel	1085.50	1080.07	1074.64	1069.22
Water	189.00	189.00	189.00	189.00
Superplasticizer	2.22	2.22	2.22	2.22
Steel Fibers	0	39.25	78.50	117.75

2.3 Workability test

To explore the effect of steel fiber presence in fresh concrete and study the development in consistency and workability, a slump test was performed. Tests were examined based on ASTM C143/C143M – 15a [19]. All the mixes, control mix, and mix that contains steel fibers were placed and compacted by a steel rod in the cone.

2.4 Hardened concrete test

All the specimens were compacted by mechanical vibrator, demolded after 24 hours, denoted, and submerged in water. Figure 2 represents the specimens used for the hardened concrete test.



Figure 2. Hardened concrete tests specimens

2.4.1 Compressive strength test

Familiar standard cubes $150 \times 150 \times 150$ mm were utilized according to BS EN 12390- 3:2019 [20]. The specimens were protected by using polyethylene sheets to avoid any possible moisture loss. After 24 hours from concreting time, the specimens were de-molded and placed in an equipped tank filled up with faucet water until testing age (28 Days).

2.4.2 Flexural strength test

Flexural strength is considered using the outcomes found from a third-point loading prism test consistent with the ASTM C78-02 [21]. The tested prisms of a dimension $(150 \times 150 \times 500)$ mm were concreted, kept wet, and submerged in the water at the same conditions for the compressive strength specimens. The specimen under test is shown in Figure 3.

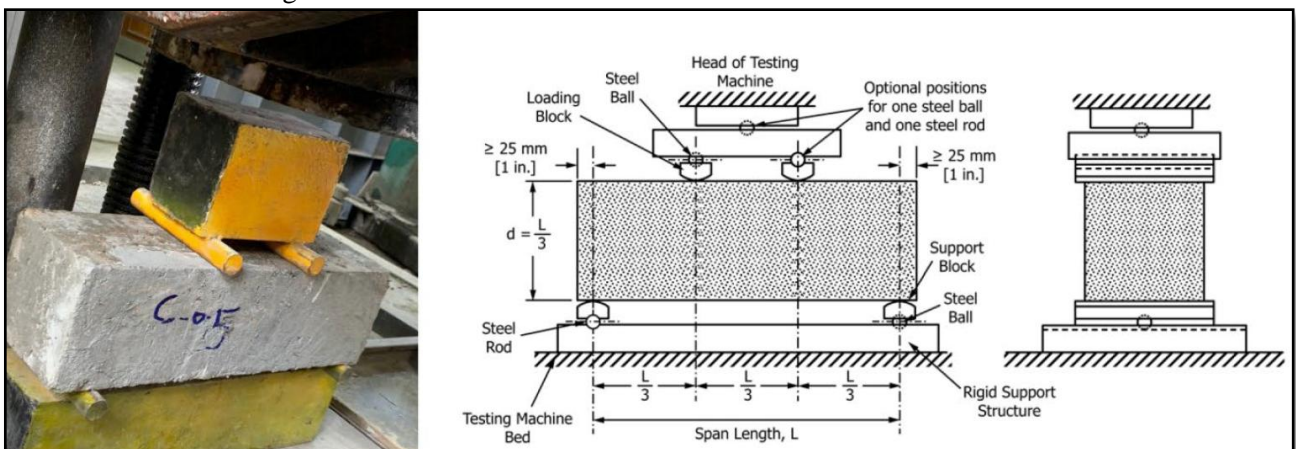

Figure 3. Flexural strength test

2.4.3 Cylinder splitting test

Standard cylinders 150 x 300 mm were utilized, according to ASTM C496-04 [22], for obtaining tensile strength. After 24 hours from the concreting, the specimens were demolded and placed in the curing container. After 28 days the specimens were tested until the splitting load was recorded as shown in Figure 4.



Figure 4. Splitting tensile test

2.5 Slabs details

Ten slabs designed to fail in flexure were cast with dimensions of 800 × 800 × 100 mm. Five Ø 12mm rebars were used identically in each direction. Slab covers from the sides and bottom were sustained as 20mm from the end bar edge. Slabs are classified into three groups each group contains three slabs. Slabs are classified based on steel fiber types. The volumetric fractions of the separate fiber type are the only varying aspect within the individual group. Figure 5 and Table 4 present slabs details.

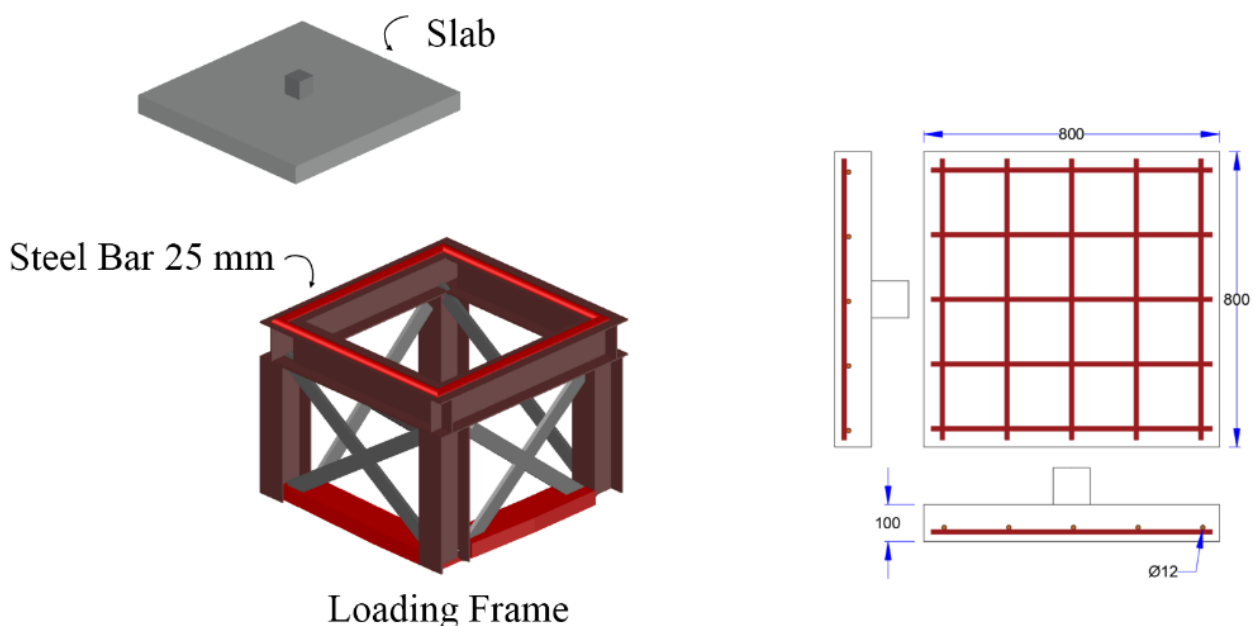

Figure 5. Slab details and loading frame

Table 4. Slabs details

Slabs	Steel Amount	Dimension mm	Loading Pedestal	Steel Fiber Shape	Steel Fiber Percentage
Control Slab	5 \varnothing 12 mm Identical in Each Direction	800 x 800 x 100 mm	200 x 200 x 100 mm	NA	0.00%
S - S 0.5				Straight	0.50%
S - S 1					1.00%
S - S 1.5					1.50%
H - H 0.5				Hooked	0.50%
H - H 1					1.00%
H - H 1.5					1.50%
C - C 0.5				Corrugated	0.50%
C - C 1					1.00%
C - C 1.5					1.50%

3. Experimental results

3.1 Fresh concrete results (Workability Results)

Adding steel fibers to fresh concrete has affected concrete workability. The results showed that for all types of steel fibers, the fresh concrete went less workable as the amount of steel fiber increased. The workability degraded by (4.76-26.19) %, (47.62-61.90) %, and (83.33-92.86) % due to changing fiber shape for the fiber volume fraction of (0.5, 1, 1.5) % respectively. However, the straight steel fibers cause lesser workable concrete with comparison to the other two types at the volume fraction of (0.5 – 1) %, while for 1.5 % fiber content, corrugated fibers degrade the workability more than the other types. The hooked fibers were the less contributor to the workability reduction of concrete. It was concluded that for all types of fibers at 1% content, the reduction in concrete workability was within the limits. Table 5 and Figure 6 show the results for slump tests measurements and workability reduction ratios for all mixes.

Table 5. Slump tests measurements

Description	Slump Test Values, cm				Slump result (workability) reduction (%)		
	No Fiber Control	Straight	Hooked	Corrugated	Straight	Hooked	Corrugated
Fiber Content 0.00 %	21.00 cm	NA	NA	NA	NA	NA	NA
Fiber Content 0.50 %	NA	15.50 cm	20.00 cm	18.00 cm	26.19%	4.76%	14.29%
Fiber Content 1.00 %	NA	8.00 cm	11.00 cm	10.00 cm	61.90%	47.62%	52.38%
Fiber Content 1.50 %	NA	2.50 cm	3.50 cm	1.50 cm	88.10%	83.33%	92.86%

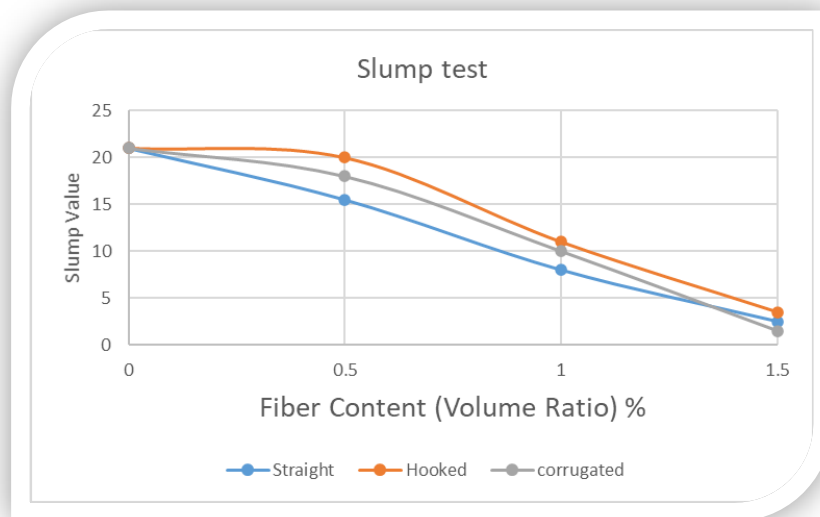

Figure 6. Slump test measurements

3.2 Hardened concrete results

3.2.1 Compressive strength

The results of tested standard cubes (15 x 15 x 15) cm showed that the compressive strength increases as the fiber content increases. For the three types of fibers in a row at the fibers contents of (0.5%, 1%, and 1.5%), the compressive strength was raised to the control samples by (9.42-14.68) %, (21.05-25.21) %, and (26.32-31.86) %, respectively. The results show that the best type for raising concrete compressive strength was the straight fibers and owing to the small size of straight fibers as it spread throughout the mixture homogeneously and consistently. The hooked fibers were the lesser contributor among the types. In general, it can be observed that the fibers contents greater than 1 % have less effect on concrete compressive strength increase. Table 6 and Figure 7 compressive strength values and increase ratios for all mixes.

Table 6. Compressive strength readings

Description	Compressive Strength Values, MPa				Compressive Strength Increase (%)		
	Control Mix	Straight	Hooked	Corrugated	Straight	Hooked	Corrugated
Fiber Content 0.00 %	36.10 MPa	NA	NA	NA	NA	NA	NA
Fiber Content 0.50 %	NA	41.40 MPa	39.50 MPa	40.30 MPa	14.68%	9.42%	11.63%
Fiber Content 1.00 %	NA	45.20 MPa	43.70 MPa	44.50 MPa	25.21%	21.05%	23.27%
Fiber Content 1.50 %	NA	47.60 MPa	45.60 MPa	46.20 MPa	31.86%	26.32%	27.98%

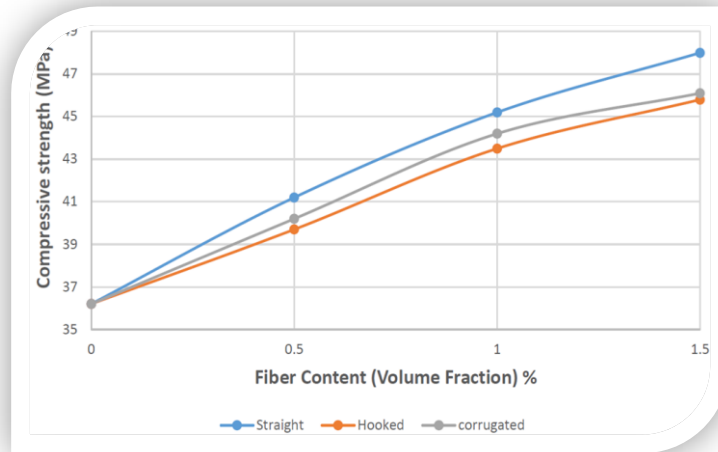

Figure 7. Compressive strength results

3.2.2 Flexural strength

The results of the tested standard prism (150 x 150 x 500 mm) showed that the flexural strength increases as the fiber content increases. For the three types of fibers and the fibers contents of (0.5%, 1%, and 1.5%), the flexural strength was increased above the control samples by (17.35-45.78) %, (53.49-109.88) % and (76.39-111.57) %, respectively. The results show that the distinguished type of fibers that more contribute to improving flexural strength were the hooked fibers, the reason behind this observation is that the shape of the hooked ends which hold or exhibit the crack development for limits due to their excellent overlapping and higher resistance against slip. The same results were obtained for compressive strength; the fibers contents greater than 1 % have less effect on flexural strength increase. Table 7 and Figure 8 illustrate the ratios of flexural strengths to the compressive strengths.

Table 7. Flexural strength values

Description	(Modulus of Rapture Values), MPa			
	Control Mix	Straight	Hooked	Corrugated
Fiber Content 0.00 %	4.15	NA	NA	NA
Fiber Content 0.50 %	NA	4.87	6.05	5.41
Fiber Content 1.00 %	NA	6.37	8.71	7.52
Fiber Content 1.50 %	NA	7.32	9.45	8.78

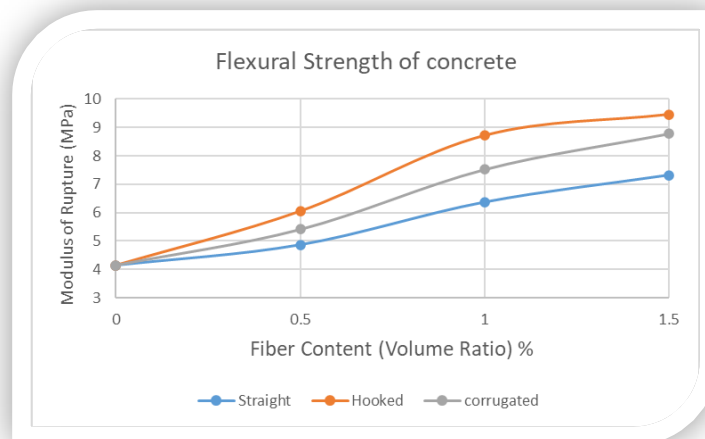

Figure 8. Proportion of flexural strength to the compressive strength

3.2.3 Splitting tensile strength

The results of the tested standard cylinder (30 x 15) cm showed that the splitting tensile strength increases as the fiber content increases. In comparison to the control sample the strength increased by (36.99-51.22) %, (58.94.87-24.80) % and (75.61-99.19) % for the three types of fibers (Straight, Hooked, and Corrugated, respectively) at fibers contents of (0.5%, 1%, and 1.5%), respectively. The increase of splitting tensile strength was subjected to fibers shapes, the hooked type was the more contributor, the corrugated was the second and the lesser was the straight type. Table 8 and Figure 9 illustrate the ratios of splitting tensile strengths to the compressive strengths.

Table 8. Splitting tensile strength values

Description	Splitting Strength, MPa			
	Control Mix	Straight	Hooked	Corrugated
Fiber Content 0.00 %	2.46	NA	NA	NA
Fiber Content 0.50 %	NA	3.37	3.72	3.51
Fiber Content 1.00 %	NA	3.91	4.62	4.22
Fiber Content 1.50 %	NA	4.32	5.34	4.9

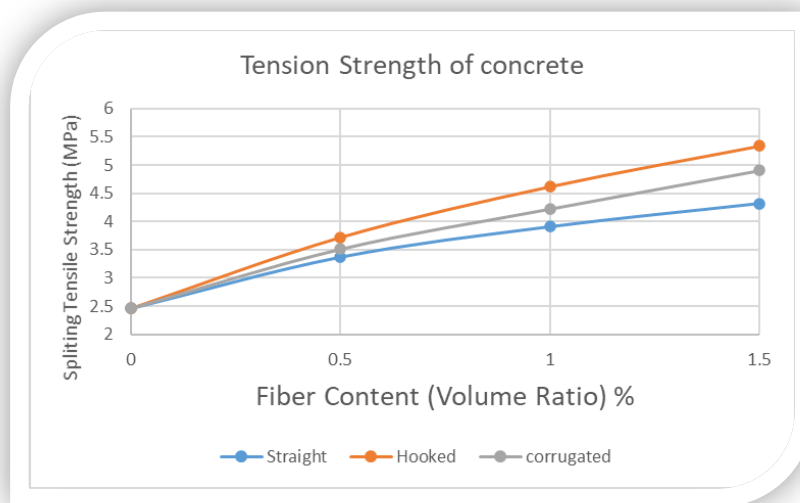

Figure 9. Proportion of splitting tensile strength to the compressive strength

3.3 Flexural behavior

3.3.1 Cracking and ultimate loads

In general, all the slabs were of flexural failure type, in the other words, adding steel fibers to the concrete did not change the failure type from flexural to punching shear regardless of the type and added quantity. Cracks started from the center of the slabs, and by stepping up the loading, the cracks travel crossly towards the slab corners, equally cross the whole tension side as illustrated in Figure 10 As the failure load approached, the deflection propagated rapidly. The first cracks began at (P_{cr}) of (20 to 32) % of the ultimate flexural load (P_u). The slabs with steel fibers have the same behavior as the control slab except that the crack, in general, took longer to appear as a result of flexural resistance increase due to fibers contribution. In general, the steel fibers content and type affect the starting and expansion of cracks significantly, Table 9 shows the cracking and ultimate loads for the slabs.

Table 9. Slabs cracking and ultimate load

Slabs	Steel	Dimension mm	Steel Fiber Shape	Steel Fiber	Pcr kN	Pu kN	Pcr / Pu	(9)*	(10)**
Control Slab	5 Ø 12 mm Identical in Each Direction	800 x 800 x 100 mm	NA	0.00%	32.01	155.00	20.65%		NA
S - S 0.5			Straight	0.50%	41.50	190.00	21.84%	29.66%	22.58%
S - S 1				1.00%	50.00	210.00	23.81%	56.21%	35.48%
S - S 1.5				1.50%	57.96	230.00	25.20%	81.08%	48.39%
H - H 0.5			Hooked	0.50%	45.00	170.00	26.47%	40.59%	09.68%
H - H 1				1.00%	65.00	222.50	29.21%	103.08%	43.55%
H - H 1.5				1.50%	85.00	262.50	32.38%	165.56%	69.35%
C - C 0.5			Corrugated	0.50%	39.90	165.00	24.18%	24.66%	06.45%
C - C 1				1.00%	49.00	200.00	24.50%	53.09%	29.03%
C - C 1.5				1.50%	63.11	240.00	26.30%	97.17%	54.84%

* Increase in the cracking load of slabs with fibers concerning control slab cracking load.

** Increase in the ultimate load of slabs with fibers concerning control slab ultimate load.

It can be concluded that for the uncracked stage, (in this stage the fiber reinforced concrete owns a distinct role in concrete resistance as the concrete is not yet cracked, by mean; the complete slab section is involved in slab strength and stiffness), the hooked fibers were the undisputed type in pulling the concrete together and delay the crack appearance. The hooked fibers increase the cracking load by 40.59%, 103.08%, and 165.56% for (0.5%, 1%, and 1.5%) fractions respectively, which are approximately twice the increase ratios given by straight and corrugated fibers. On the other hand, the type of the fibers has had a clear effect on the ultimate flexural capacity (Pu) of the slabs but by a close proportion among the three types irrespective of the fibers contents.

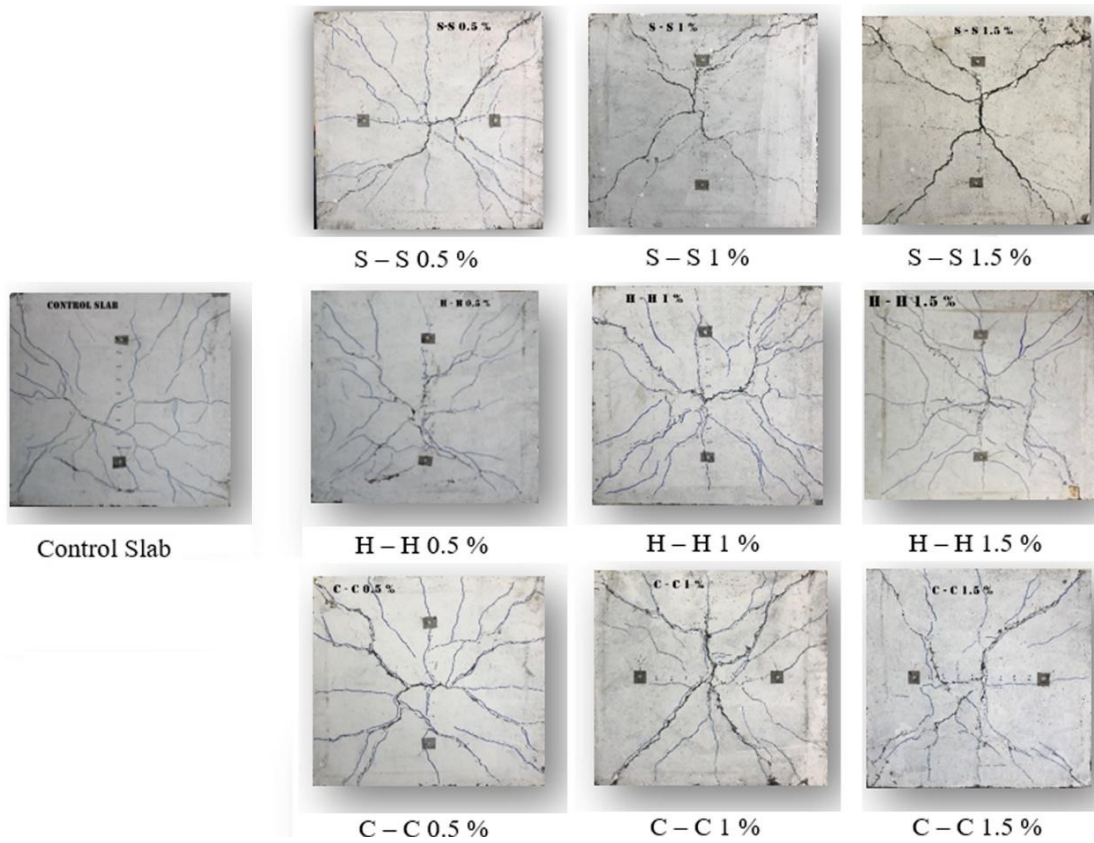

Figure 10. Slabs crack pattern

3.3.2 Slabs load-deflection relations

The max observed deflections in this article represent the max recorded deflections (mid-span deflections) before the slabs collapse, in order not to damage the measuring tools. Adding the steel fibers makes the slab produce proportionally fewer deflections at the same loading level as the fibers make the slab stiffer. The curves became wider inclination after the first crack popped up, owing to the formation of the major first crack reduced slab stiffness significantly, therefore the deflection was of the higher rate. The load-deflection curves of the slabs contain fibers was receding toward load axis as the loading continued, crack became wider, and more cracks produced.

The ultimate recorded deflections of the three contents (0.5%, 1%, and 1.5%) were increased by 26.88%, 41.75%, and 48.75% for hooked fibers, while were 2.00%, 20.75%, and 25.00% for straight fibers, and 5.00%, 11.00%, and 29.13% for corrugated fibers, respectively.

From the load-deflection records, it can be extracted that the effect of steel fibers type can be described whereas the slab contains hooked fibers bias to produce higher ultimate deflection before failure occurred and that correct for all fiber contents (0.5%, 1%, and 1.5%), but with different increase ratios. This observation can be attributed to the shape of the ends which can be hooked inside the concrete and retard the crack development due to proportionally higher bond strength. A similar observation was obtained for flexural tests specimens.

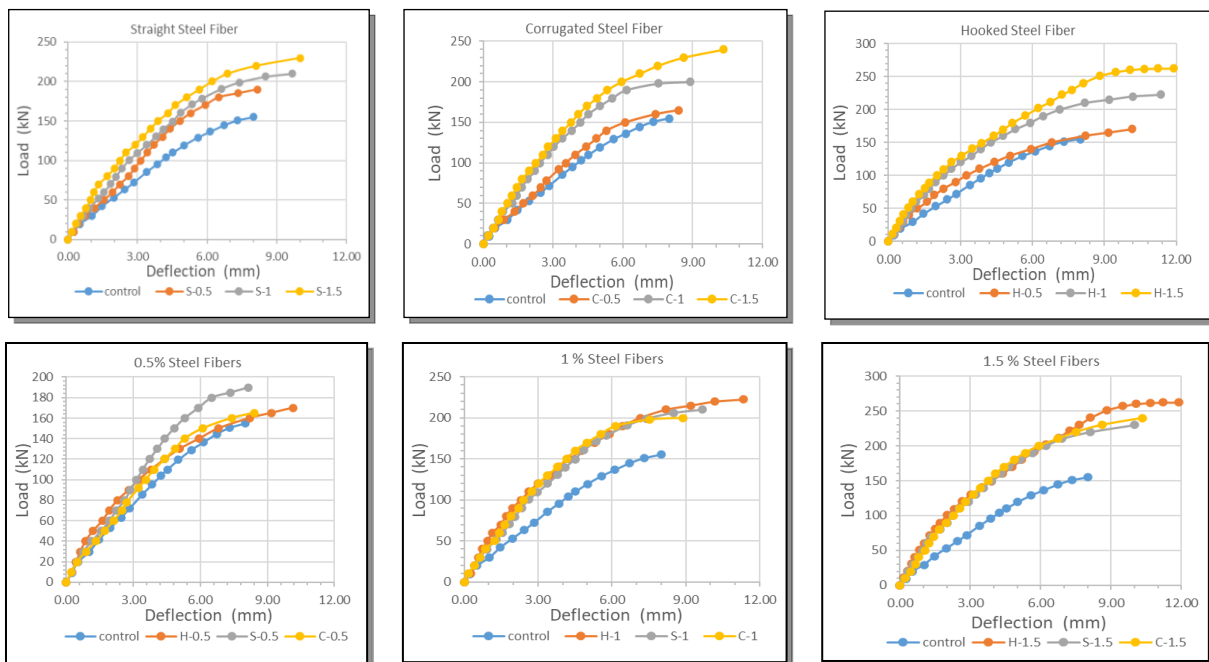

4.

Figure 11. Slabs load-deflection curves (deflections measured at mid-span)

5. Conclusions

- Steel Fibers reduce the concrete workability, the reduction within the limits up to 1% content.
- Steel fibers increase compressive F_{cu} , tensile F_t , and flexural F_r strengths, the recommended fiber content is 1%.
- Steel fibers increase the first cracking load by 56%, 104%, and 53% over the control slab cracking load for Straight, Hooked, and Corrugated fibers respectively, when 1% of fibers content was added, and that make the hooked fibers is the best choice for strengthening the flexural zones at the uncracked stage.

- Steel fibers increase slab ultimate strength by 35%, 43%, and 29% for straight, hooked, and corrugated fibers respectively, at a content of 1%, and from that, a conclusion can be made that all type of fibers increases the ultimate strength by close ratios.
- Steel Fibers sustain their presence as a strength improver at uncracked (increase cracking load) and cracked stage (increase ultimate capacity).
- For all fibers types, the general flexural behavior and cracks pattern are almost the same except the cracks with fibers are narrower and earlier cracks take longer to appear.
- Straight fibers provide a notable improvement to the concrete at 0.5% addition contrasted to other types and that can be attributed to the small size of this type which makes the fibers blend and incorporate sound with the concrete.
- Slabs containing steel fibers induce lower deflection at the same loading level for all fibers types and volumetric content.
- Utilize hooked fibers to make the slabs further stiffer and induce higher ultimate deflection before the collapse. 48.75% increase above the control slab ultimate deflection when 1.5% of hooked fibers were added.

6. References

- [1] Mohd. Gulfam Pathan and Ajay Swarup, 2017, "A Review on Steel Fiber Reinforced Concrete," International Journal of Advance Research in Science and Engineering, Vol 6, special issue No. 1.
- [2] ASTM A820 / A820M, 2016, "Standard Specification for Steel Fibers for Fiber-Reinforced Concrete,".
- [3] Mustafa Shareef Zewair, Ahid Zuhair Hamoodi, Mohammed Farhan Ojaimi, 2021, "Effect of types of fibres on the shear behaviour of deep beam with opening," Periodicals of Engineering and Natural Sciences, Vol. 9, No. 2, pp.1086-1095, 2021.
- [4] Hang T.N. Nguyen, Kang Hai Tan, Tetsushi Kanda, 2020, "Effect of polypropylene and steel fibers on web-shear resistance of deep concrete hollow-core slabs," Engineering Structures 210 110273, 2020.
- [5] Esraa Khudhair Mohsin Abuzaid, 2019, "Behavior and Strength of Steel-CarbonPlastic Hybrid Fiber Reinforced Concrete Beams," Second International Conference on Sustainable Engineering Techniques (ICSET 2019).
- [6] Kaize Ma, Ting Qi, Huijie Liu, and Hongbing Wang, "Shear Behavior of Hybrid Fiber Reinforced Concrete Deep Beams," Material (Basel), Vol. 11, Oct. 2018.
- [7] Nafisa Tabassum, Pranta Biswas, Dr. Md. Saiful Islam and Dr. Md. Moinul Islam, 2018, "A Study on The Compressive & Flexural Strength Behavior of Steel Fiber Reinforced Concrete Beam," International Journal of advanced research (IJAR).
- [8] Sivakumar Anandan, Saiful Islam, and Roohul Abad., 2018, "Characteristics of Steel Fiber Reinforced High Strength Concrete Beams Efficiency in Size Reduction for Flexure," Engineering Journal Volume 22 Issue 4.
- [9] V. Prabhu and Jessy Rooby, 2018, "Behavior of Steel Fiber Reinforced Concrete Beam Using Fly Ash," International Journal of Civil Engineering and Technology (IJCIET) Volume 9.
- [10] Muyasser Jomaa'h, Ammar Khazaal, and Sinan Ahmed, 2018, "Effect of replacing the main reinforcement by steel fibers on flexural behavior of one-way concrete slab," College of Engineering, Tikrit University, Tikrit, Iraq.
- [11] Joshua A. McMahon, Anna C. Birely, 2018, "Service performance of steel fiber reinforced concrete (SFRC) slabs," Elsevier, Engineering Structures volo. 168, pp.58–68, 2018.
- [12] Gediminas Marciukaitis and Remigijus Slna, 2017, "Calculation of punching shear strength of steel fiber reinforced concrete flat slabs," Elsevier, Procedia Engineering vol. 172, pp. 1110 – 1114, 2017.
- [13] David Fall et al, 2014, "Two-way slabs: Experimental investigation of load redistributions in steel fiber reinforced concrete, Engineering Structures," December 2014.

- [14] R. Kandasamy and R. Murugesan, 2011, "Fiber Reinforced Concrete Using Domestic Waste Plastic as Fiber," *Journal of Engineering and Applied Sciences* Vol. 6, No. 3.
- [15] ASTM C150/C150M, 2020, "Standard Specification for Portland Cement,".
- [16] ASTM C33/C33M, 2018. "Standard Specification for Concrete Aggregates,".
- [17] Iraqi Standards No.5/1984, "Ordinary Portland cement," Ministry of Housing and Construction, Baghdad, 2004.
- [18] ASTM A615, 2005, "Standard Specification for Deformed and Plain Carbon-Steel Bars for Concrete Reinforcement," *Annual Book of American Society for Testing Concrete and Materials*, Philadelphia, Pennsylvania.
- [19] ASTM C143/C143M-20, "Standard Test Method for Slump of Hydraulic-Cement Concrete,".
- [20] BS EN 12390- 3:2019, "Testing hardened concrete. Determination of the carbonation resistance of concrete. Accelerated carbonation method,".
- [21] ASTM C78-02, "Standard Test Method for Flexural Strength of Concrete (Using Simple Beam with Third-point Loading)," , Vol. 4, no. 2, pp. 1-3, 2002.
- [22] ASTM C496, 2004, "Standard Test Method for Splitting Tensile Strength for Cylindrical Concrete Specimens," *American Society for Testing and Materials*.