

Development of PIM Components for Robot Surgery

Dong Yong Park

Department of Mechanical Engineering POSTECH,
77 Cheongam-ro Pohang, South Korea

Fehim findik

Division of Engineering and Natural Sciences
International University of Sarajevo, Sarajevo
Bosnia-Herzegovina

Seong Jin Park

Department of Mechanical Engineering POSTECH,
77 Cheongam-ro Pohang, South Korea

Abstract

In this study, the micro forcep of end-effector for robot surgery was produced by powder injection molding. The 17-4PH stainless steel powder and binder system based on a wax-polymer were mixed to fabricate the feedstock. The optimum solid loading (vol. %) was determined by the torque rheometer experiments. After injection molding, debinding and sintering were carried out, final product having small and regular patterns was produced.

Keywords: μ -PIM, end-effector, and robot surgery

1. Introduction

Micro powder injection molding (μ -PIM) technology combined by plastic injection molding and conventional powder metallurgy has been known as a near net shaping technology suitable for the fabrication of micro-components [1]. This technology has many advantages including shape complexity, tight tolerances, and material selection of metals or ceramics. Once desired materials, mold geometries, and process parameters are decided, PIM is an appropriate process for the mass production. The PIM process consists of four steps; (i) mixing – producing the pelletized feedstock of the powder and organic binders, (ii) molding – injecting the feedstock melt into the mold cavity, similar with thermoplastics; (iii) debinding – extracting or removing the organic binders out of injection molded part via solvents or the thermal energy, (iv) sintering – densifying the debound part from the low initial density to the high final density, close to the full density [2]. Figure 1 shows a schematic diagram of the PIM process.

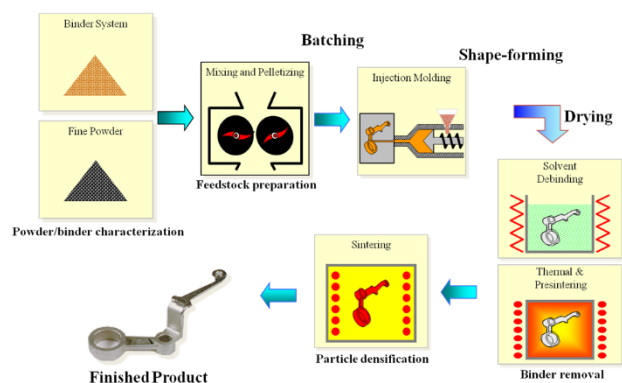

Figure 1. schematic diagram of powder injection molding [3].

In this regards, μ -PIM technology is employed to produce medical devices such as an endo-tip for the dental application and an end-effector for the robot surgery. Figure 2 shows the endo-tip for dental application made by CetaTech Inc.

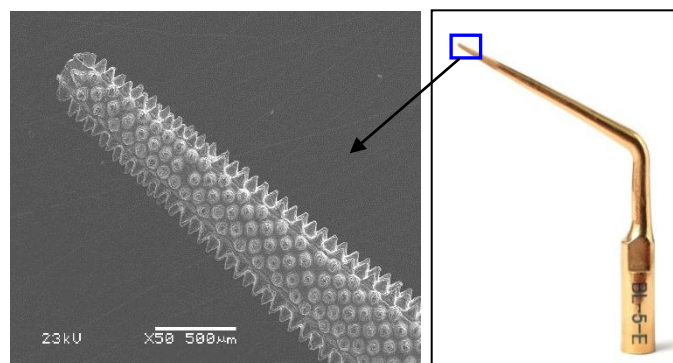

Figure 2. Dental application (Courtesy by CetaTech Inc., Korea).

2. Experimental Procedures

The water-atomized stainless steel powders of type 17-4PH were prepared with PF-15F (8.30 μ m) produced by Atmix Inc. The particle characteristics of SUS17-4PH are given in Table 1. The powder was mixed with wax-polymer binder system including wax, polypropylene (PP), polyethylene (PE), and stearic acid (SA). The mechanical properties of the binder system is summarized in Table 2. The optimum solid loading (vol. %) was determined by the torque rheometer experiment. Mixing was carried out to produce feedstock by the twin-extruder type of mixer (CetaTech Inc.). All samples were debound to remove the binder. After solvent debinding, all samples were thermally debound and pre-sintered via following thermal cycles; temperature has been increased by

Table 1. The characteristics of powder

Powder	particle size (μm)			Distribution slope parameter (S_w)	Apparent density (g/cm ³)	Tap density (g/cm ³)	True density (g/cm ³)
	D_{10}	D_{50}	D_{90}				
PF-15F	3.22	8.30	19.47	3.28	3.08	4.20	7.75

Table 2 Material properties of binder ingredients

	Wax	PP	PE	SA
Density (g/cm ³)	0.90	0.90	0.92	0.94
Melting point (°C)	42 - 62	110-150	60 - 130	74 - 83
Decomposition temperature (°C)	180 - 320	350 - 470	420 - 480	263 - 306

ramping from 30 °C to 900 °C at 2 °C/min with intermediate 2-hour holds at 250 °C, 450 °C, and 700 °C using the tube furnace. The injection molded samples were debound at 60 °C for 10 hours in a *n*-Hexane solution. The debound samples were sintered in a H₂ atmosphere. In order to predict the densification behavior during sintering, dilatometry experiments were conducted. Figure 3 shows the thermal history of dilatometry experiments. The densification behavior was analyzed.

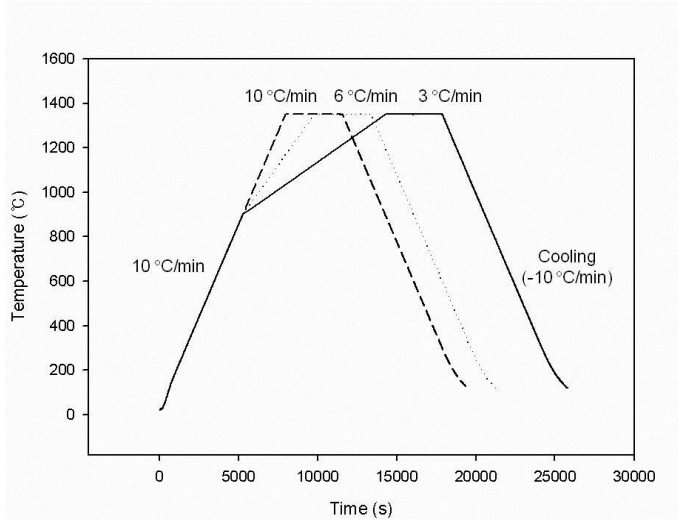

Figure 3. Thermal history of dilatometry experiments.

3. Results and Discussions

The optimum solid loading (vol. %) which is a balanced mixture of powder and binder can determine success or failure of subsequent PIM processes. To determine the optimum solid load, torque rheometer experiments were carried out. The torque was measured by adding 1 % of solid loading for each step at the temperature of 150 °C. The critical solid loading where the particles are tightly

packed and remaining space filled with binder was determined at the solid loading of 63 % as shown in Figure 4. The optimum solid loading is considered as approximately 2 – 5 lower value than critical solid loading. In this study, we determined the solid loading set by 59 vol. %.

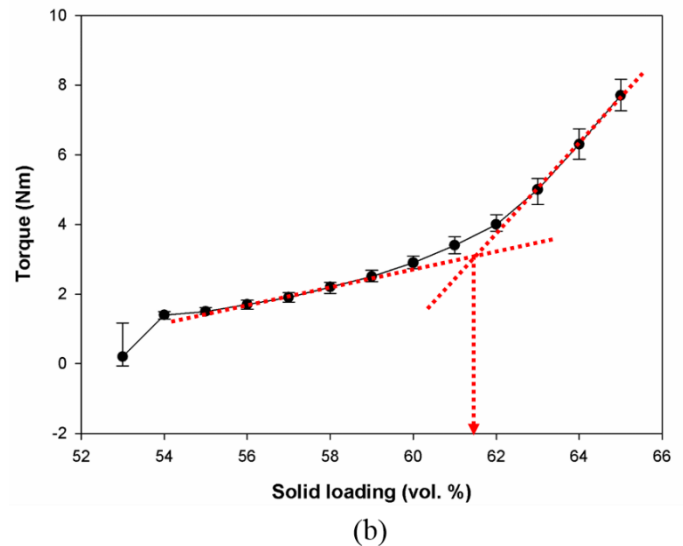
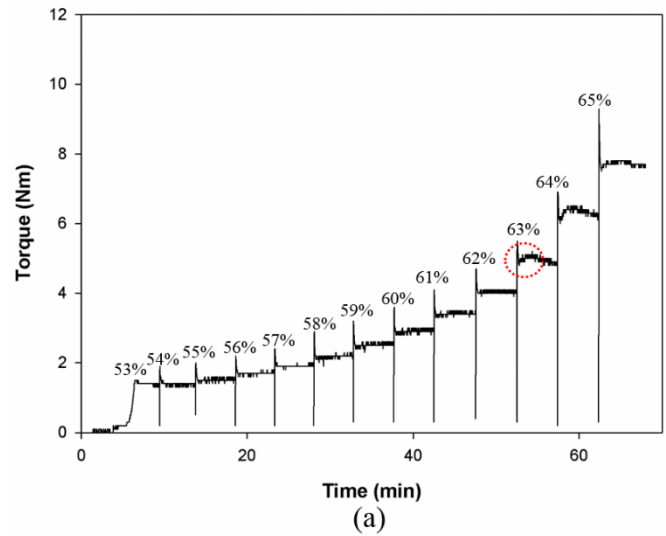

Figure 4. Mixing torque, (a) as a function of time, and (b) as a function of solid loading.

A forcep for robot surgery was designed using Solid Works. As shown in Figure 5, end-effector for robot surgery has the small and complex shape. Small components with complex geometries can be more economically produced by PIM technique. In order to

design the mold for injection molding, the shrinkage during sintering has to be considered to obtain the precise dimension of final components.

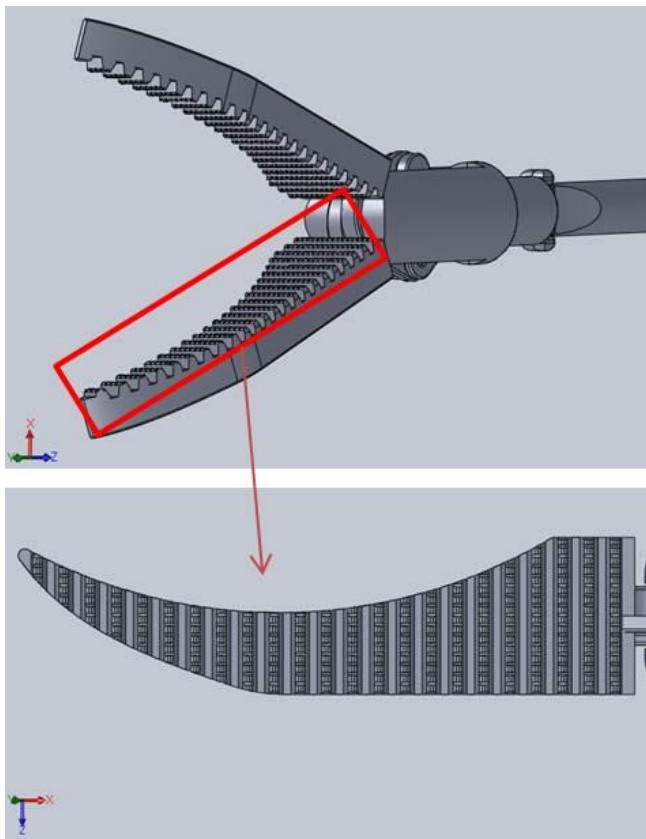

Figure 5. designed end-effector for robot surgery.

In this regard, dilatometry experiments were conducted to measure the *in situ* shrinkage during sintering. Figure 6 shows the shrinkage behavior for given sintering conditions.

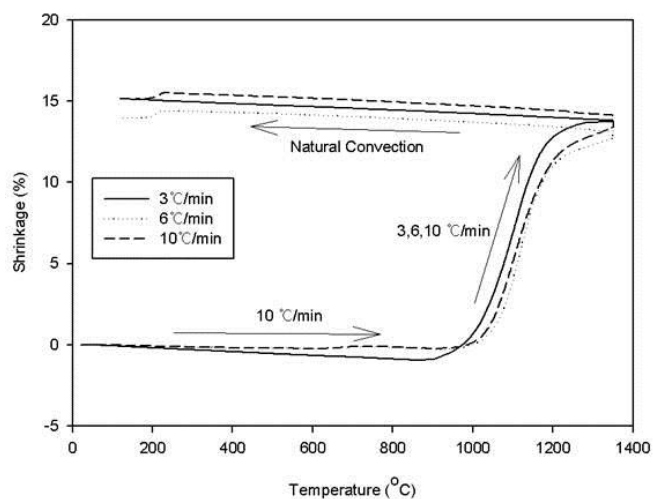

Figure 6. Shrinkage behavior for given sintering conditions.

The shrinkage, after sintering, is approximately 15 %. The feedstock was injection molded into the designed mold. Figure 7 shows the green, brown, and sintered parts for end-effector.



Figure 7. Green, brown, and sintered parts for the forcep of end-effector.

The injection molded samples (green part) were debound at 60 °C for 10 hours in a *n*-Hexane solution to remove the binder. After solvent debinding, thermal debinding and pre-sintering were carried out. Finally, debound samples (brown part) were sintered in H₂ atmosphere. The dimension of sintered components were shrunk as expected.

Conclusions

The end-effector for robot surgery was produced by PIM technique. Considering that the forcep of end-effector has the complicated shape, the PIM is a suitable method to produce the medical device with complex geometry.

Acknowledgements

This work was supported by the National Research Foundation of Korea (NRF) grant funded by the Korea government (MSIP) (No. 2011-0030075).

References

- [1] German, R.M. and A. Bose, "Injection molding of metals and ceramics." Metal Powder Industries Federation 1997.
- [2] Liu, L., N.H. Loh, B.Y. Tay, and S.B. Tor, "Microstructure evolution of 316L stainless steel micro components prepared by micro powder injection molding." *Powder Technology*, vol. 206, no. 3, pp. 246-251, 2011.
- [3] Park, D.Y., S.W. Lee, S.J. Park, Y.-S. Kwon, and I. Otsuka, "Effects of Particle Sizes on Sintering Behavior of 316L Stainless Steel Powder." *Metallurgical and Materials Transactions A*, vol. 44, no. 3, pp. 1508-18, 2013.