

## Image watermarking based on framelet transform

Nora H. Sultan<sup>1</sup>, Noor Hassan Abed Khammas<sup>2</sup>, Ziadoon Hassan Najm<sup>3</sup>

<sup>1</sup>Department of Computer Sciences, College of Education for Girls, Kufa University, Iraq

<sup>2,3</sup> Department of Electronic and Communication, College of Engineering, Kufa University, Iraq

---

### ABSTRACT

Watermarking is used mostly for multimedia data copyright protection. This paper introduces the Transformation Framelet (FLT) for watermarking digital images. In this technique, the FLT is used to create an original image and watermark the low (LL) frequency subband of an original image in LL subband of an image watermarking. Simulation results demonstrate, in terms of a wide range of traditional attacks, that this approach is imperceptible and stable. MATLAB software version 2014 was used for simulation. Experiments on gray scale and colored images were performed in this work.

---

**Keywords:** Framelet transform, Mean square error, Peak signal to noise ratio, Wavelet transform, Watermarking image

---

### *Corresponding Author:*

Nora H. Sultan  
Department of Computer Sciences,  
College of Education for Girls, Kufa University, Iraq  
E-mail: [norah.mayali@uokufa.edu.iq](mailto:norah.mayali@uokufa.edu.iq)

---

## 1. Introduction

The new fields of computer science, encryption, signal processing and communication are digital watermarking technology [1]. In addition to data coding and scrambling to secure information, digital watermarking is developed by its creators as a solution to the requirement of providing added value protection. Generally speaking, a digital watermark is a technology that enables a person to add secret copyright or other verifying information to digital media [2,3]. Two popular watermarking methods exist: a spatial domain and a domain transformation. Depending on the perceptual analysis of an image, pixels are changing in the space domain [4,5]. However, some frequencies have been selected in transform domain and adjusted according to some rules from their original values. The methods of transforming the domain are common as the embedding of watermarks is more robust than spatial domain. More protection and imperviousness are also given [3,6,7]. Watermarking is used in the frequency domain by the application of transforms such as the DFT, the DCT, and the DWT [8,9] Discrete Transformation of Wavelet [9,10]. Many researchers implemented hybrid method, the DCT-SVD watermarking mechanism, capable of enhancing the robustness and invisibility of watermarked images [11,12,13]. This hybrid mechanism has been developed by several researchers.

This paper proposes a system based on FLT watermarking which functions in the domain of transformation. The document is set accordingly. The DWT scheme is included in Section 2. The FLT technique has been included in section 3, the suggested algorithms have been included in section 4, while experimental findings in section 5.

### 1.1. DWT

As shown in Figure 1(a), DWT subbands divide the image into four subbands. Such subbands consist of horizontal-vertical filter applications which are separately applicable. Detailed images are coefficients defined as LH1, HL1 and HH1 subbands, and coefficients as LL1 is an image approximation. In order to achieve a subsequent degree of wavelet parameters depicted in Figure 1(b), the sub-band LL1 has further decomposed [14,15].

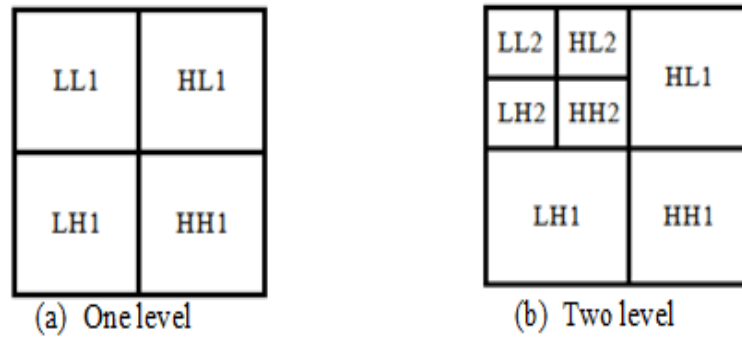

Figure 1. Decomposition DWT

Figure 2 (a & b) explains that a filter bank structure for (2D analysis DWT in addition to 2D synthesis DWT) correspondingly.

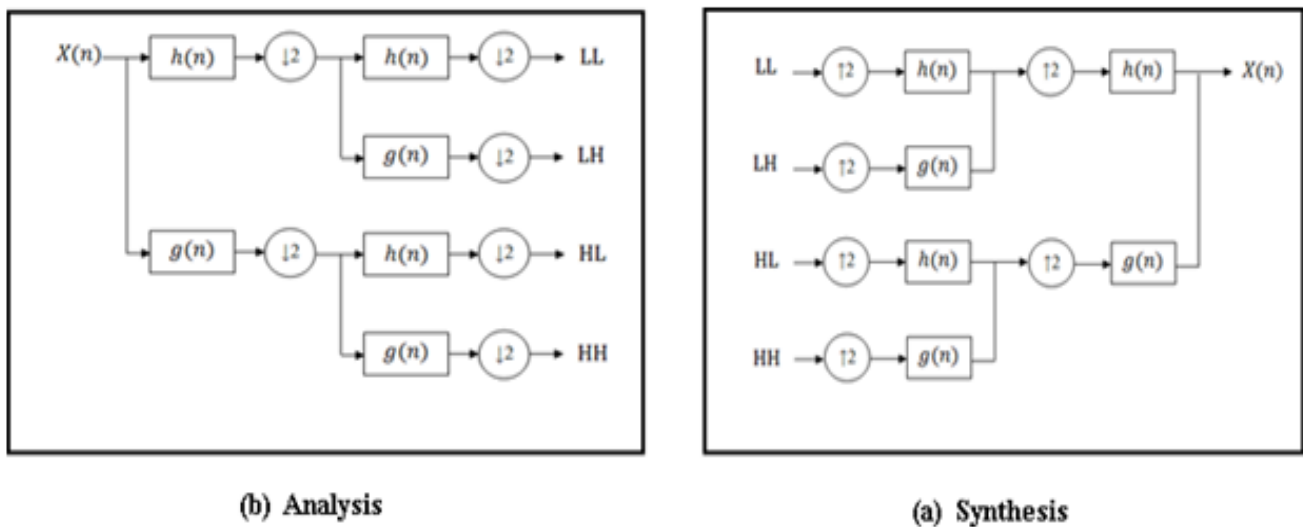

Figure 2. Filter bank for 2D - DWT analysis and synthesis [14]

### 1.2. FLT

The three-channel filter bank, which has employed for developing the FLT related to a wavelet frame using one scaling function  $\phi(t)$  and dual distinctive wavelets  $\Psi_1(t)$  and  $\Psi_2(t)$ . The additional wavelet at this point creates this structure an overcomplete one. It follows that  $\phi(t)$ ,  $\Psi_1(t)$  and  $\Psi_2(t)$  satisfies a dilation and wavelet equations [16, 17,18].

$$\phi(t) = \sqrt{2} \sum_n h_0(n) \phi(2t - n) \tag{1}$$

$$\Psi_i = \sqrt{2} \sum_n h_i(n) \phi(2t - n) \quad i = 1\&2 \tag{2}$$

A scaling function  $\phi(t)$  and the wavelets  $\Psi_1(t)$ ,  $\Psi_2(t)$  have outlined via these equations using a lowpass (scaling) filter  $h_0(n)$  and the dual high pass (wavelet) filters  $h_1(n)$  and  $h_2(n)$ , where the dual distinct wavelets  $\Psi_1(t)$  and  $\Psi_2(t)$  have been specifically considered to be offset from each other by one half as follows:

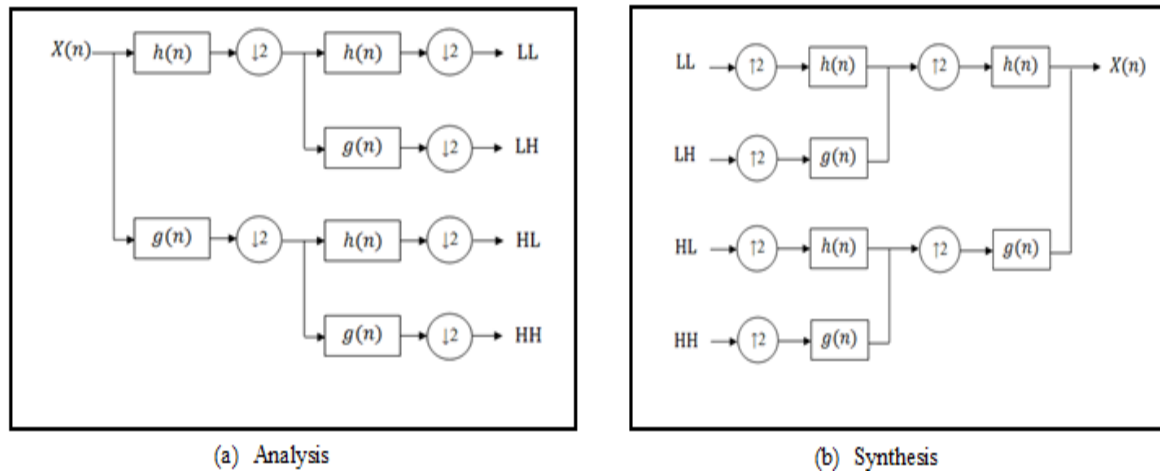

Figure 3. Filter bank for 2D- DWT Analysis and Synthesis [19]

$$\Psi_1(t) \cong \Psi_2(t - 0.5) \tag{3}$$

Where the filters  $h_1(n)$  and  $h_2(n)$  should satisfy the Perfect Reconstruction (PR) condition. This means that the input and output of the two filters are expected to be the same [20,21].

**1.2.1. Filter bank structure for 2D framelet**

The transform should first be used on the rows, then on the columns of the resulting matrices in order to perform the FLT on 2D Matrix. The results are nine two-dimensional subbands, one of which is the 2-D low-pass scaling filter and eight of them, as shown in Figure 4, form the eight 2-d wavelet filter [19].

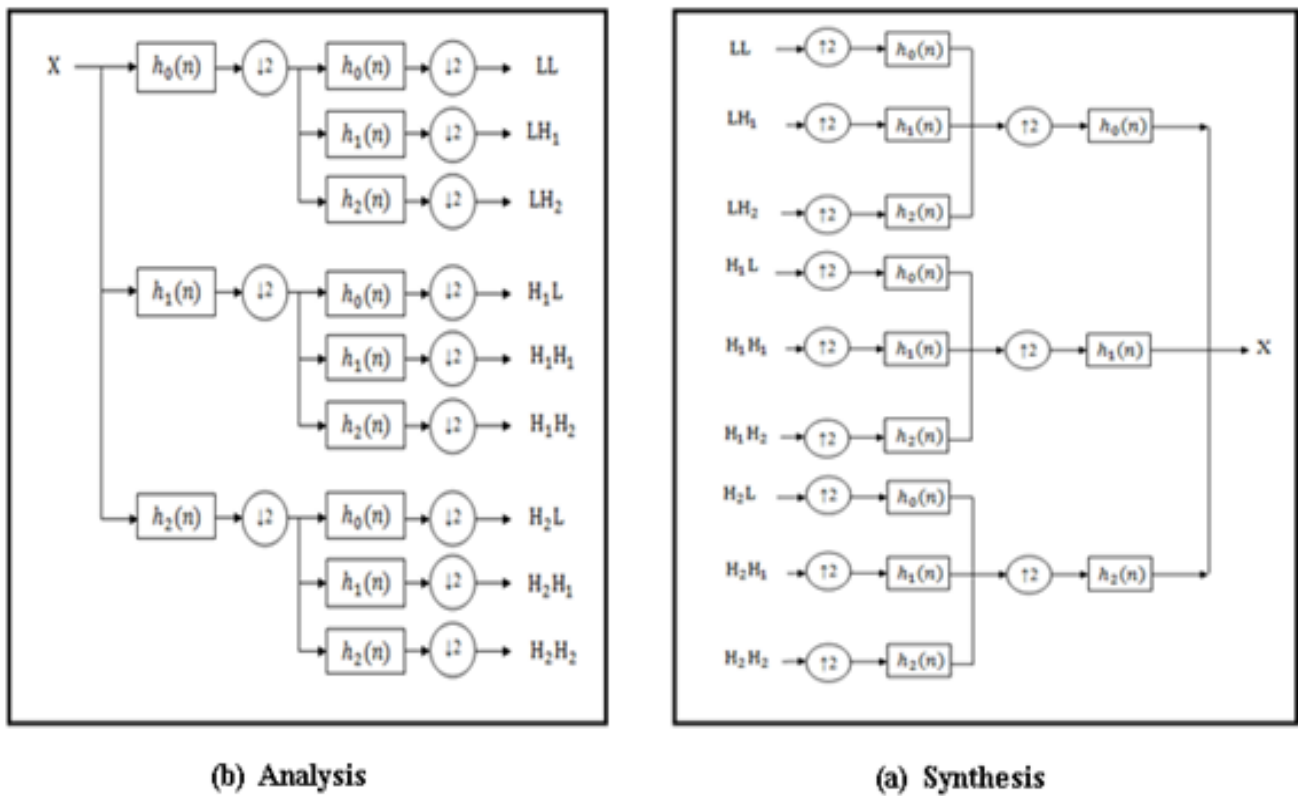

Figure 4. Filter bank for 2D- DWT Analysis and Synthesis [19]

### 1.2.2. Computational of FLT For 2-D signal using separable method

By alternating rows and columns it is possible to generate a separable 2-D FLT that is, each line is processed in order and the result column is then processed. In both matrix sizes non-separable methods operate simultaneously. A 2-D transform is analogous to a serial transformation of two 1-D transformations. The transformation of 1-D row, then of a 1-D column, is implemented with data gotten from the transformation of the row. The next steps should be followed to calculate a single, discrete transform framelet for a 2-D signals with separable method [19]:

- a) Investigating dimensions: Input matrix must be in  $N \times N$  size, in which  $N$  should be even and equal or greater to the length based on analysis filters.
- b) Build the transformation matrix: Designed for an  $N \times N$  matrix input for 2-D signal  $X$ , create  $\frac{3N}{2} \times N$  transformation matrix,  $W$ , by means of length-7 coefficients filter (for example) given as [19]:

$$W = \begin{bmatrix} h_0(0) & h_0(1) & h_0(2) & h_0(3) & h_0(4) & h_0(5) & h_0(6) & 0 & 0 & \dots & 0 & 0 \\ 0 & 0 & h_0(0) & h_0(1) & h_0(2) & h_0(3) & h_0(4) & h_0(5) & h_0(6) & \dots & 0 & 0 \\ \vdots & \vdots & \vdots & \vdots & \vdots & \vdots & \vdots & \vdots & \vdots & \vdots & \vdots & \vdots \\ h_0(2) & h_0(3) & h_0(4) & h_0(5) & h_0(6) & 0 & 0 & \dots & 0 & 0 & h_0(0) & h_0(1) \\ h_1(0) & h_1(1) & h_1(2) & h_1(3) & h_1(4) & h_1(5) & h_1(6) & 0 & 0 & \dots & 0 & 0 \\ 0 & 0 & h_1(0) & h_1(1) & h_1(2) & h_1(3) & h_1(4) & h_1(5) & h_1(6) & \dots & 0 & 0 \\ \vdots & \vdots & \vdots & \vdots & \vdots & \vdots & \vdots & \vdots & \vdots & \vdots & \vdots & \vdots \\ h_1(2) & h_1(3) & h_1(4) & h_1(5) & h_1(6) & 0 & 0 & 0 & 0 & \dots & h_1(0) & h_1(1) \\ h_2(0) & h_2(1) & h_2(2) & h_2(3) & h_2(4) & 0 & 0 & 0 & 0 & \dots & 0 & 0 \\ 0 & 0 & h_2(0) & h_2(1) & h_2(2) & h_2(3) & h_2(4) & 0 & 0 & \dots & 0 & 0 \\ \vdots & \vdots & \vdots & \vdots & \vdots & \vdots & \vdots & \vdots & \vdots & \vdots & \vdots & \vdots \\ h_2(2) & h_2(3) & h_2(4) & 0 & 0 & 0 & 0 & 0 & 0 & \dots & h_2(0) & h_2(1) \end{bmatrix} \frac{3N}{2} \times N$$

- c) Transformation of the input rows by the multiplication of the matrix by the  $N$  to  $N$  input matrix to the built  $3N/2$  to  $N$  transform matrix.

$$Y = [W]_{\frac{3N}{2} \times N} \times [X]_{N \times N} \tag{4}$$

- d) Input column transformation: can be carried out in [19,22] the following way:
  - i. Transpose a row transformed  $\frac{3N}{2} \times N$  matrix based on step (3).
  - ii. Employ matrix multiplication for  $\frac{3N}{2} \times N$  created transformation matrix based on  $N \times N$  column matrix.

$$YY = [W]_{\frac{3N}{2} \times N} \times [Y]_{N \times \frac{3N}{2}}^T \tag{5}$$

The transformed matrix of the final structure is t:

$$Y_0 = [YY]_{\frac{3N}{2} \times \frac{3N}{2}}^T \tag{6}$$

### 1.2.3. Computation of IFLT for 2-D signal via separable and non- separable methods

Inverse Framelet Transform (IFLT) can be used to recreate a fundamental signal from a transformed discrete framelet signal. For computing the single level 2-D inverse and discrete framelet transformation with a separable

process, the next steps are followed [19,23]. The transformation matrix stands for a reverse transformation matrix, since a transformation is orthogonal;

- a) Assume  $Y_0$  to be  $\frac{3N}{2} \times \frac{3N}{2}$  framelet transformed matrix.
- b) Make  $N \times \frac{3N}{2}$  reconstruction matrix, by means of transpose of transformation matrix,  $[W]^T$ .
- c) Reforming of columns based on applied matrix multiplication to  $N \times \frac{3N}{2}$  reconstruction matrix in accordance with  $\frac{3N}{2} \times \frac{3N}{2}$  framelet transformed matrix.

$$YYX = [W]_{N \times \frac{3N}{2}}^T \times [Y_0]_{\frac{3N}{2} \times \frac{3N}{2}} \quad (7)$$

- d) Reforming rows are prepared based on the following:
  - i. Transpose the column reconstructed matrix resulting from step (3).

$$YX = [YYX]_{\frac{3N}{2} \times N}^T \quad (8)$$

- ii. Employ matrix multiplication through multiplying a reconstruction matrix with a consequential transpose matrix.

$$XX = [W]_{N \times \frac{3N}{2}}^T \times [YX]_{\frac{3N}{2} \times N} \quad (9)$$

$$X = [XX]^T \quad (10)$$

For computing the single level inverse FLT for 2-D signal based on non-separable method, the subsequent steps must be as following:

- 1) Assume  $Y_0$  to be  $\frac{3N}{2} \times \frac{3N}{2}$  framelet transformed matrix.
- 2) Make  $N \times \frac{3N}{2}$  reconstruction matrix  $W^T$  using transformation matrix.
- 3) Reform an input matrix through multiplying a reconstruction matrix based on input matrix and through transposing a reconstruction matrix.

$$X = W^T \times Y_0 \times W \quad (11)$$

A single-stage framelet transformation consists of nine frequency bands. These subbands have shown in Figure 5. Since  $L$  is a low-pass filter  $h_0(n)$ , whereas  $H_1$  and  $H_2$  stand for highpass filters ( $h_1(n)$  and  $h_2(n)$ ), the  $H_1 H_1, H_2 H_1, H_1 H_2$  and  $H_2 H_2$  subbands, every has a frequency-domain support analogous to  $HH$  subband in a DWT. A comparable system makes the  $H_1 L, H_2 L, LH_1$  and  $LH_2$  subbands with the identical frequency-domain support as an equivalent  $HL(LH)$  subbands of the DWT, but with two times as several parameters. Lastly, there is merely single subbands  $LL$  with an identical frequency-domain as the  $LL$  subbands in DWT [19].

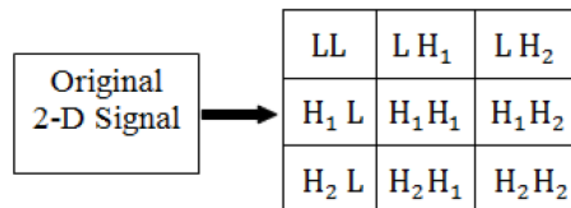

Figure 5. Matrix subbands subsequent to a single-level decomposition FLT

## 2. Projected procedure

Figure 6 (a & b) depicts the flowchart of projected algorithm:

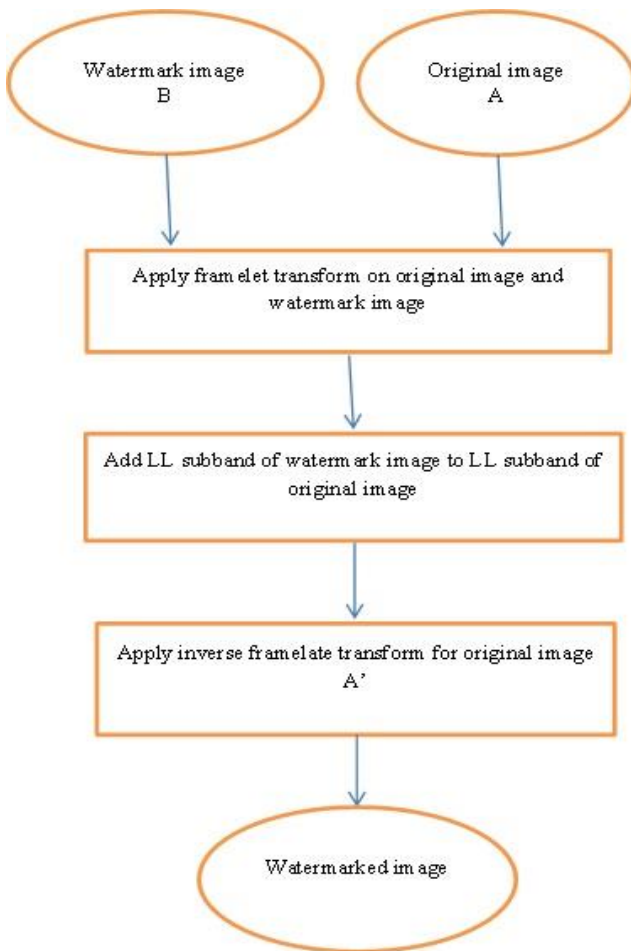

Figure 6. (a) proposed image watermarking

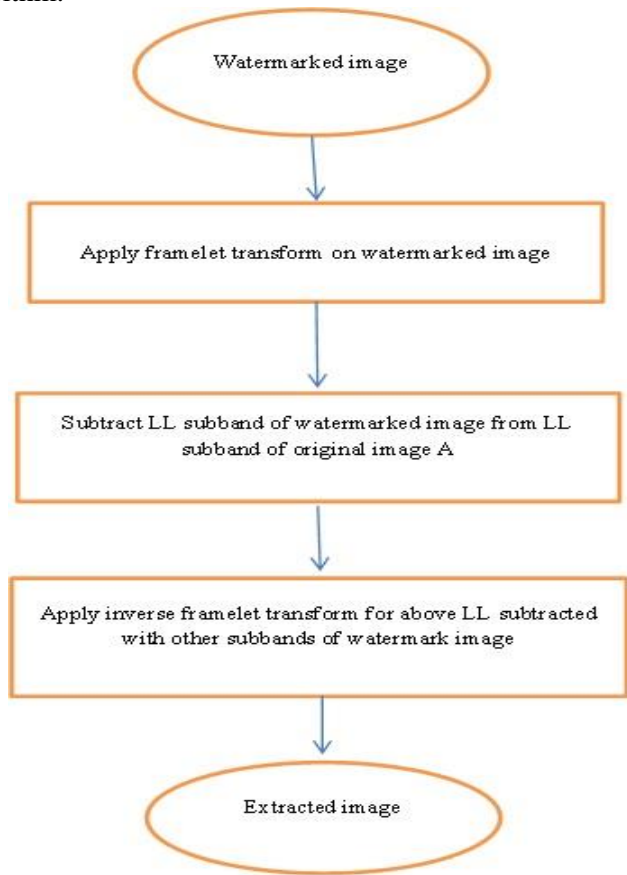

Figure 6. (b) Proposed algorithm for extracted image

In this work, 1-level FLT is applied on the original and watermarking image, then adding the LL of watermarking image to LL of original image, then apply inverse framelet transform to get watermarked image. Then to get the extracted image, must be subtracted the LL of watermarked image from LL of original image then apply the inverse of FLT on the result. And this algorithm is proposed for watermarking the color images. First the RGB colors images are converted into  $Y C_b C_r$  form, then employing the projected algorithm on every layer individually, this means each layer from  $Y C_b C_r$  stands for watermarking as a gray scale image. Figure 7 shows that proposed algorithm is applied on each  $Y C_b C_r$  layer.

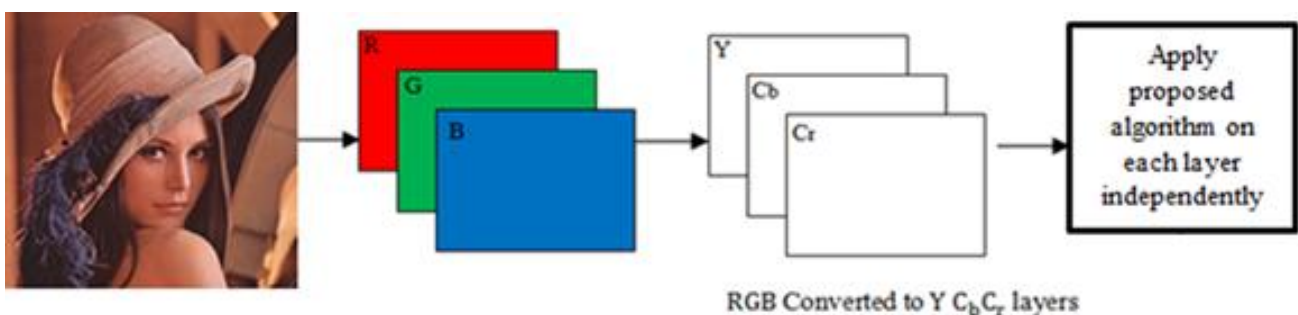

Figure 7:RGB layers are converted to  $Y C_b C_r$  Layer, and then watermarking by proposed Algorithm

### 3. Results and Discussion

Figure 8 depicts some gray scale images with proposed algorithm and the results in Table 1 shown the performance of PSNR and MSE compared with other algorithms



Figure 8. Results of gray scale images for proposed algorithm

Table 1. Performance comparison between proposed algorithm and other algorithms for lena image in Figure 8 with watermarking eye image

Proposed Algorithms	PSNR	MSE
using FLT	34.6442	21.0983
using wavelet transform (db5)	34.6408	21.1156
using wavelet transform (haar)	34.6394	21.1063

Figures 9-11 have shown the results of other gray scale images with proposed algorithm.

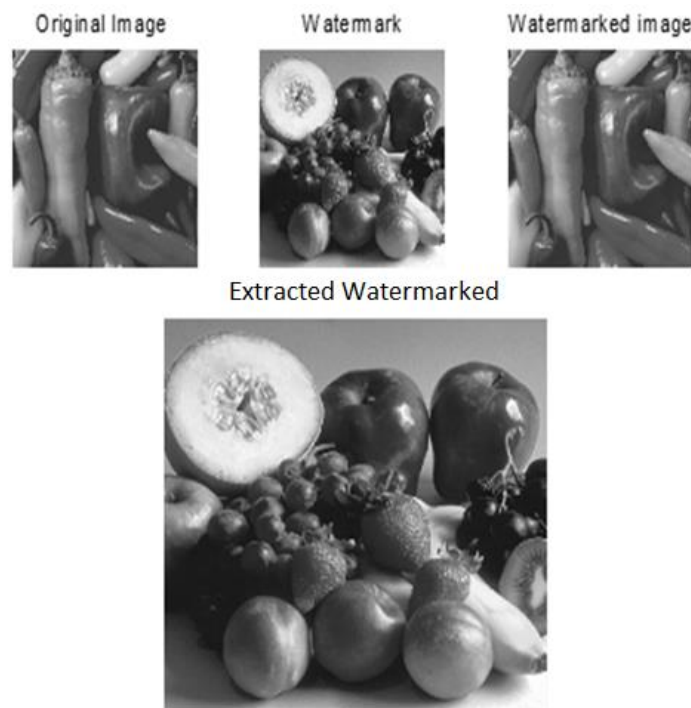

Figure 9. Fruits images with proposed algorithm



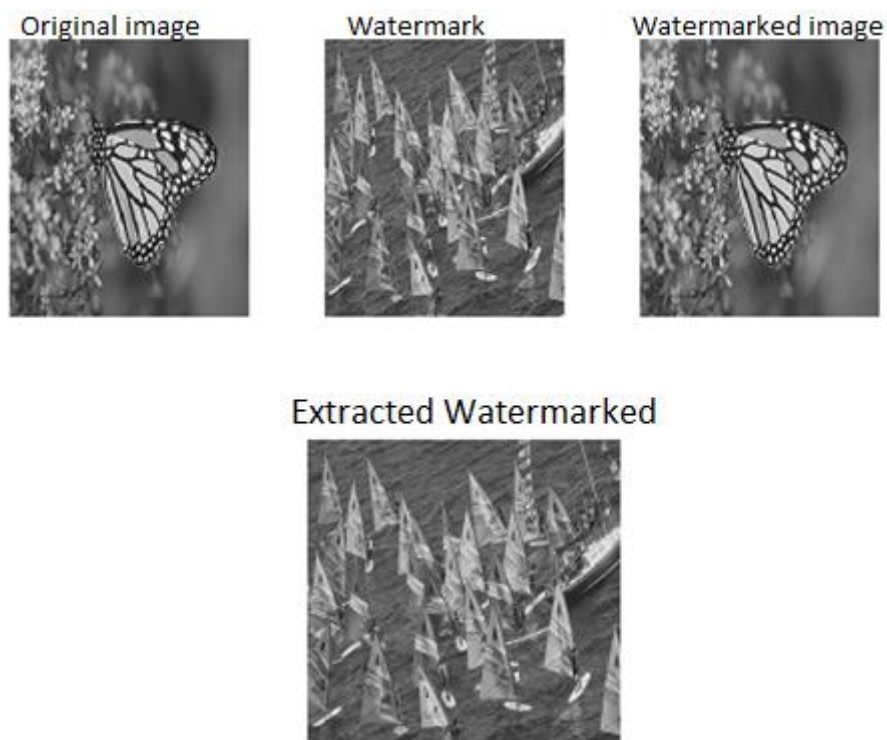

Figure 10. Some gray images with proposed algorithm

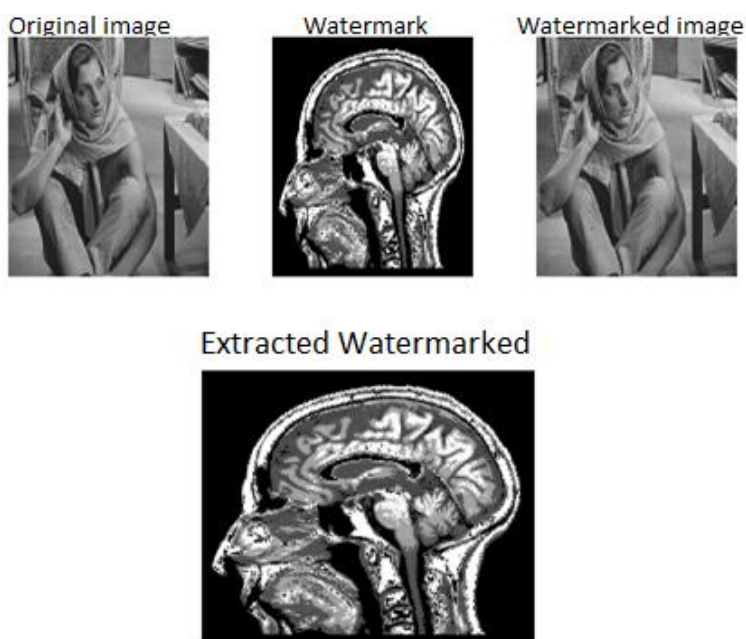

Figure 11. Medical image with gray image

Table 2 has shown the performance of PSNR as well as MSE for gray scale images in the Figures 9,10 &11

Table 2. Consequences of PSNR as well as MSE for gray scale images in the Figures 9,10 &11

Images	Psnr	Mse
Images in Figure.9	36.4313	14.8610
Images in Figure.10	37.5068	11.9714
Images in Figure.11	36.8491	11.7975



Figures 12, 13 and 14 have shown the results of colored images with proposed algorithm.



**Extracted Watermarked**



Figure 12. Some color images with proposed algorithm



**Extracted Watermarked**



Figure 13. Some color images with proposed algorithm

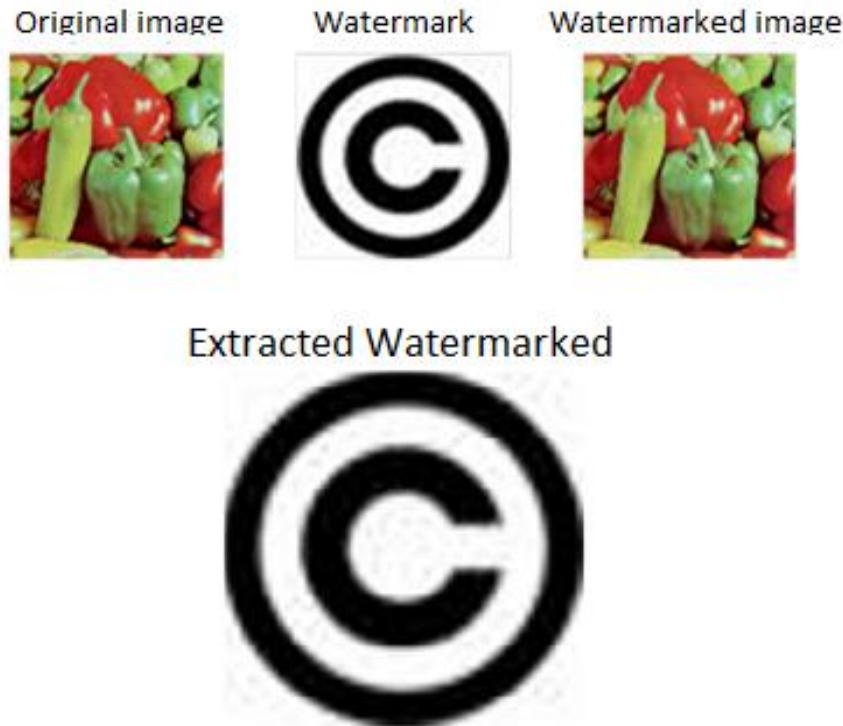

Figure 14. Some color images with proposed algorithm

Table 3 depicts the performance of PSNR as well as MSE for color images in the Figures 12,13 and 14

Table 3. Consequences of PSNR as well as MSE for colored images in Figures 12-14

Images	PSNR	MSE
Images in Figure.12	33.7251	29.2516
Images in Figure.13	33.3273	32.0644
Images in Figure.14	39.1591	7.8297

#### 4. Conclusion

Framelets have been successfully used in noise reduction and painting as well as for high-resolution image restoration and video improvement. Framelet transform was then used in the traditional method instead of the DCT and DWT transform. In conclusion, it has been shown that the Framelet with image watermark in this algorithm gives best output between DWT and other algorithms using the MATLAB software program.

#### References

- [1] Ch.I. Podilchuk & E.J.Delp,"digital watermarking: algorithms and applications", *IEEE signal processing Magazine*, vol.18, no.4, pp.33-46, 2011.
- [2] B. Ram" Digital Image Watermarking Technique Using Discrete Wavelet Transform and Discrete Cosine Transform" *International Journal of Advancements in Research & Technology*, vol. 2, no.4, April-2013.
- [3] Sh. Saxena, R. Jain & Sh. K. Shandilya,"Result Analysis of Reliable RGB Color Image Watermarking using DWT and DCT, " *IDES joint International conferences on IPC and ARTEE*, 2017
- [4] M. Narang & Sh. Vashisth" Digital Watermarking using Discrete Wavelet Transform" Department of electrical, electronics & communication engineering, ITM University Sec-23a, Gurgaon, *International Journal of Computer Applications*, vol. 74, no. 20, 2013.

- [5] M. Prathapaneni and G. Reddy "Non-blind watermarking Scheme for Colour Images using Discrete Wavelet Transforms and Singular Value Decomposition", *International Journal of Innovative Research in Science, Engineering and Technology*, vol. 4, no. 4, April 2015
- [6] A.F.ELGamal,N.A.Mosa & W.K.ALSaid" Block-based Watermarking for Color Images using DCT and DWT" Department of computer science, Mansoura university, Egypt. *International Journal of Computer Applications*, vol. 66, no.15, 2013.
- [7] Y. Zolotavkin & M. Juhola"SVD-based Digital Image Watermarking on approximated Orthogonal Matrix" *In Proceedings ofthe10thInternationalConferenceonSecurityandCryptography*, pp. 321-330, 2013.
- [8] K. J. Giri " A Robust Color Image Watermarking Scheme Using Discrete Wavelet Transformation, *IJ Image, Graphics and Signal Processing*, vol.1, pp. 47-52 ,2015
- [9] P. Kumar & S. K. Agarwal, "A Color Image Denoising By Hybrid Filter for Mixed Noise" Department of Electronics Communication Engineering, Rustamji Institute of Technology, BSF Academy, Tekanpur, Gwalior (M.P.), India, *Journal of Current Engineering and Technology*, Vol. 5, No. 3, 2015.
- [10] F. L. Malallah1, A. A. Jafaar, N. H. Abbas & M. G. Saeed" Reversible color video watermarking scheme based on hybrid of integer-to-integer wavelet transform and Arnold transform"Computer and Information Engineering, College of Electronics Engineering, Ninevah University, Iraq, *International Journal of Electrical and Computer Engineering (IJECE)* Vol. 10, No. 4, pp. 3519~3527, 2020.
- [11] F. Ernawan, S.Ch. Liew, Z. Mustaffa & K. Moorthy "A Blind Multiple Watermarks based on Human Visual Characteristics", Faculty of Computer Systems & Software Engineering, Universiti Malaysia Pahang, Malaysia, *International Journal of Electrical and Computer Engineering (IJECE)*, Vol. 8, No. 4, pp. 2578~2587 , August 2018.
- [12] B.L. Gunjal1 & S. N.Mali"SECURED COLOR IMAGE WATERMARKING TECHNIQUE IN DWT-DCT DOMAIN",*International Journal of Computer Science, Engineering and Information Technology (IJCSIT)*, Vol.1, No.3, 2011.
- [13] F. Sarkardeh1 and M. Khalili, Effective SVD-YCBCR Color Image Watermarking", *International Journal of Computer Networks and Communications Security*, vol.3, no.3, p.2-3,2015
- [14] W. Qasim, "Optical Flow Estimation using Framelet Transform", M.Sc. Thesis, *University of Technology*, Iraq, 2010.
- [15] I. Assini, A. Badri, A. Sahel & A. Baghdad, "Hybrid multiple watermarking technique for securing medical images of modalities MRI, CT scan, and X-ray "International Journal of Electrical and Computer Engineering (IJECE) Vol. 10, No. 3, pp. 2349~2356,2020.
- [16] M. Barni, "Document and Image Compression", *Dekker Inc.*, 2004.
- [17] F. Ernawan & Dh. Ariatmanto," Image watermarking based on integer wavelet transform-singular value decomposition with variance pixels", *International Journal of Electrical and Computer Engineering (IJECE)* Vol. 9, No. 3, pp. 2185~2195, 2019,
- [18] K. Chaitanya1, E. S. Reddy & K. G. Rao," Digital Color Image Watermarking in RGB Planes Using DWT-DCT-SVD Coefficients", (IJCSIT) *International Journal of Computer Science and Information Technologies*, Vol. 5, No. 2, pp. 2413-2417, 2014.
- [19] Ziad Qais, "Framelet-based OFDM System", M.Sc. Thesis, *University of Technology, Baghdad, Iraq*, 2011.
- [20] M.Choi, "Introduction of a Symmetric Tight Wavelet Frame to Image Fusion Methods Based on Substitutive Wavelet Decomposition", *Korea Advanced Institute of Science and Technology, Korea*, 2007.
- V. A. Kumar, C. Dharmaraj & Ch. S. Rao" A Hybrid Digital Watermarking Approach Using Wavelets and LSB" *International Journal of Electrical and Computer Engineering (IJECE)*, Vol. 7, No. 5, pp. 2483~2495, October 2017.