

## Enhancement in iris recognition system using FPGA

Methaq Jasam Swadi<sup>1</sup>, Ahmed H. Ahmed<sup>2</sup>, Raaed K. Ibrahim<sup>2</sup>

<sup>1</sup> Ministry of Higher Education and Scientific Research, Baghdad, Iraq

<sup>2</sup> Al-Farahidi University, Baghdad, Iraq

---

### ABSTRACT

The growth of using the iris recognition over the globe for identification and for verification and the problem that faces the iris recognition from noise like eyelash and eyelid. This paper focus on choosing the right pattern to collect the traits. The algorithm of this paper is searching and working on different rectangle iris template to spotting the ultimate traits that lies within rectangle iris templates. The Ridge Energy Direction (RED) is used as algorithm to spot the features that lies within the template. The overall iris system is design, implemented and tested on the Field Programmable gate Area (FPGA).

**Keywords:** Ridge Energy Direction, FPGA, Iris Recognition

---

### *Corresponding Author:*

Methaq Jasam Swadi  
Ministry of Higher Education and Scientific Research  
Baghdad, Iraq  
E-mail: Methit14@gmail.com

---

### 1. Introduction

The evolution of using the biometric in the field of security specially in the airports and others checkpoints since each human has a unique trait that no one else in the global had. The biometric has skill to match between people depends on their traits such as their fingerprint, sound recognition, geography, iris recognition and etc. However, the biometric can be divided into two categories. The first category required physical contact with the devices that collect the features an example of first category is a fingerprint. The fingerprint required to touch the devices that take the traits and this may lead to infections due to the touching part of the process, in contrast the second part category don't required physical contact and depends on detecting the trait on picture that captured away from the person that required to distinguish form him [1]. An example of this category is face recognition or iris recognition and etc. However, although there are multiple of biometric that don't require to physical contact but the most vital and accurate methods among them are the iris recognition [2].

For these reasons that mentioned before the iris recognition is considered as most accurate among other biometric system. However, the iris recognition system is least used among others biometric such as face recognition system although iris recognition system is invented in the 90<sup>th</sup> of the century. The iris system is not used like other system because of it is required enormous amount of resources and required high quality digital camera so can detects the traits and features, also required powerful processor in order to process the enormous amount resources and to analysis the features [3].

In the recent decades, iris has become more used than other years because of the new develop algorithms that tried to decrease the amount of resources that needed by iris recognition system to distinguish the between people such as Ridge energy direction, Circle Hough Transform (CHT) and etc. Also, it has seen a new powerful processor invented that capable of processing the enormous amount of resources that iris system needed with no time. The invention of parallel processor makes iris recognition system faster and made the effort of making real time iris system. One of the most famous parallel processors that used in this paper is called Field Programmable Gate Area (FPGA). This processor has the capability of performing multiple process at the same clock cycle. The technology of FPGA permits to exist iris recognition system with low-cost and higher performance and works in real time application [4].

## 2. Theory

The system foundation of iris recognition system is consisted like every biometrics system from five stages. The first stages will be the templates that process will perform on it. The templates will come from scanning devices or camera. Then this template will perform to segmentation and then normalization process will perform and before the last process the features and traits extraction in features extraction. Finally, the matching process will be applied to identify these features and traits according to the similarity of these features and traits in database. The system of iris recognition is shown in Figure 1.

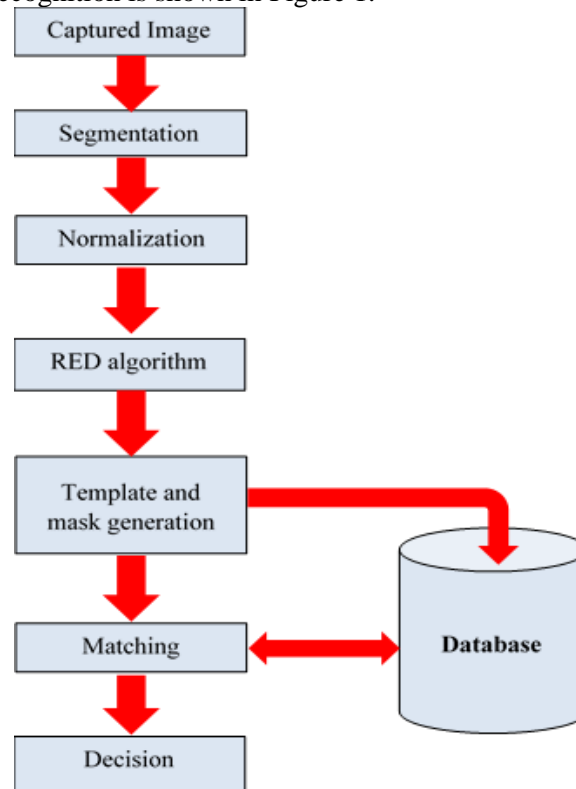

Figure 1. Iris system for recognition

## 3. Captured image

The CASCIA V1 and CASCIA interval databases are used as imaged captured [5] [6]. These databases are used due to the high-resolution images and contain various cases of iris images. Also, to test system it required to tested on different databases to verify the working of the system. Also, another device is used to test the system which is special camera that used to collected sum data and this camera is specialized for collecting iris images and high-resolution camera. The collection of images for the eye is most crucial process since it will effect on the holy process of iris recognition system. So, it is required to take eye image without noise that came from eyelid and eyelash. The lower the noise the better so it is important to took best shot for eye image

## 4. Segmentation

Segmentation name represents segment the data in order to be applied to the next stages. The segment of data is important because it will divide the data that collected from image capture in the first stage. This division will determine the data that contain the feature to be further deal with and the noise that came from eyelid and eyelash. The process or segmentation in iris recognition system is first applied edge filter and then determine the parameter of pupil and iris circle due to iris lies between these two. Then extract the iris region that and determine the location of noise [7].

The edge filter that used in this paper is canny edge filter. This filter used five steps (Gaussian smoothing process, Sobel gradient calculation, Non-Maximum Suppression, Double thresholding process, Hysteresis preprocess) as shown in Figure 2. These five steps of canny edge detection will determine the edges of pupil and iris and then will be processed by second process of segmentation [8].

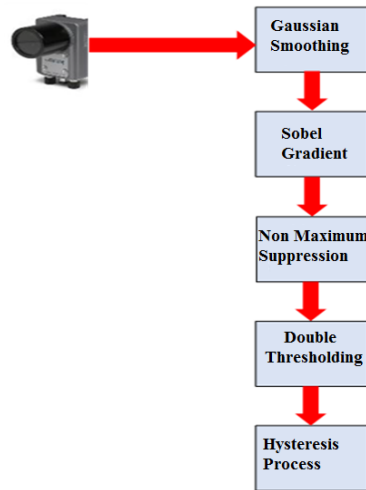

Figure 2. Canny edge algorithm

The second process in segmentation is finding circle parameters of pupil and iris based on the results of canny images. The algorithm that used to determine the parameter of iris and pupil in this paper is CHT. These parameters are the center and radius of circle of both iris and pupil. Both iris and pupil edges will show as ring like circle when applied the canny edges. The CHT is used to discover the circle of parameter of both iris and pupil. The CHT is preferred according to its simplest in working and it doesn't contain complex mathematical equation only simple mathematical equation. So that, CHT is more suitable to be applied in FPGA since the simplest of mathematical equation that can applied in VHDL language and doesn't take much data resources of FPGA system. In addition, the CHT works in parallel mode that suitable for FPGA processor due utilized the full benefit of FPGA. With every shot of applying CHT Algorithm it will generate eight different points based on the one point and this based on law of circle similarity [9]. CHT is applied as a method to determine the center and radius of both circles. The CHT will try to find the center of the iris and radius and then will located the pupil circle since the pupil is always lies within the iris so this will help in lower the time required for searching the pupil since it will search only within the iris circle boundary. In addition, the time of finding the iris is small because the circle of iris is larger than the pupil so finding it first is faster than find the pupil then find the iris boundary. A best parameter is found by CHT that fit the circle of both iris and pupil. The architecture of the CHT in FPGA in Figure 3.

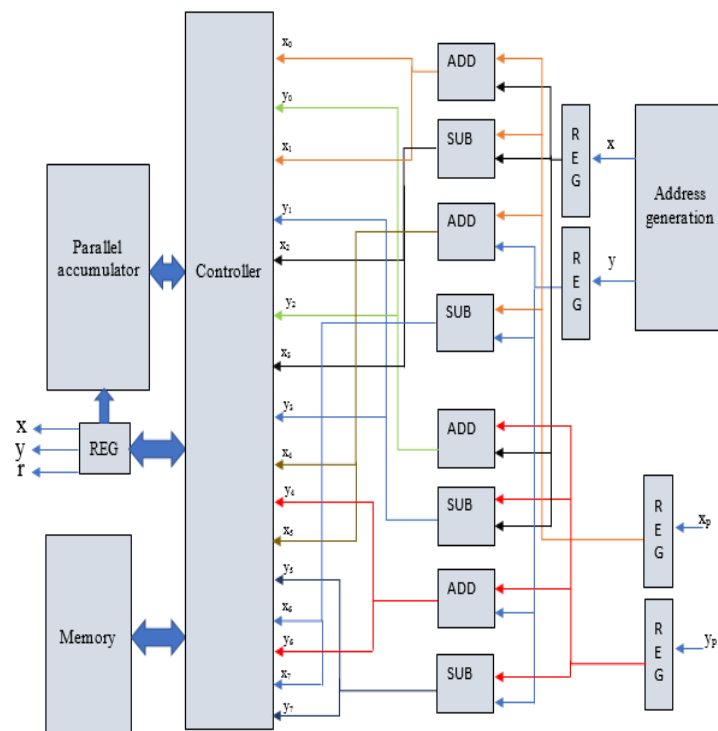

Figure 3. CHT in FPGA

## 5. Normalization

Every biometric's system needs to be normalized after the segmentation. The normalization stage in iris recognition is to convert the shapes of the iris from the circular to rectangular as shown in figure 3. The conversion is done to simplify the extraction of features from the iris template. Since the dealing with the rectangle form is easy than dealing with circular form. So, in order to convert the shapes of the iris to rectangle form, CHT is used for that purpose. The CHT is chosen based on a lot of beneficial that had. The first one that it is fastest than another algorithm that convert from the polar to rectangular [9]. The second benefit. It is compatible with FPGA since it uses the full power of FPGA parallel as mention in segmentation process. The last benefit, it's generating eight points at time by using rule of circle symmetric [10].

Four rectangle iris templates will be shaped in normalization stage. The testing and matching process will be applied according to these rectangle templates are shaped in normalization process. The first rectangle template will contain the all the features of iris. While the features that lies within the second rectangle template contains the lower part of iris. The features of the third rectangle template contains iris part that near to the pupil. Finally, the features that lies in fourth rectangle template contains the quarter iris template as shown in Figure 4.

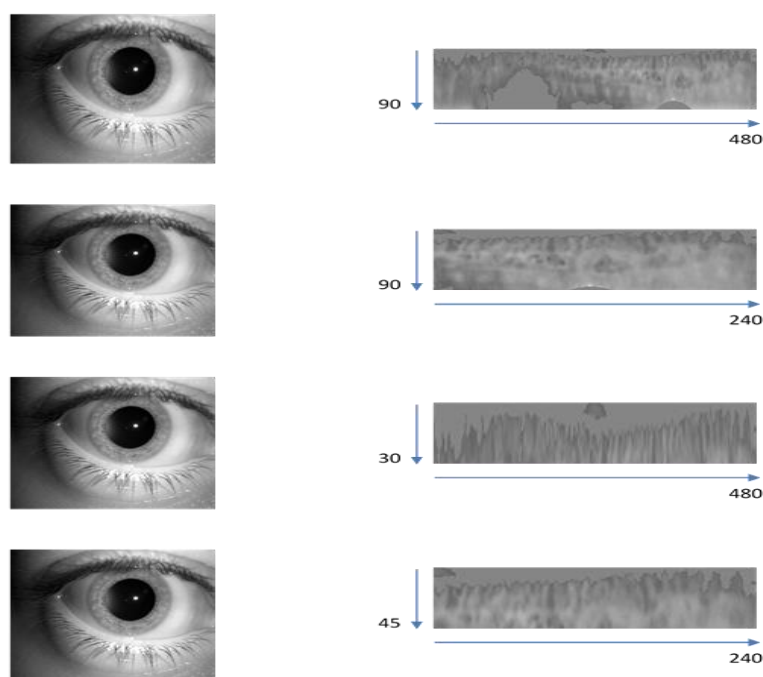

Figure 4. Iris rectangle iris template

## 6. Feature extraction

After the rectangle template is formed from the CHT of normalization process. An algorithm is performed on that template to detect the features that lies within it. The algorithm that performed for spotting and extraction the features is RED. This algorithm was chosen based on many benefits. At first, this algorithm is used digital filters rather than analog filter, which is faster to implemented on a processor and superb to detects features than analog filter that more complex in implemented on a processor. The second benefit of this algorithm is that can take the benefit of parallel processor in FPGA because the RED algorithm depends on applying 9x9 filter on each pixel in rectangle template the spotting and detecting of features in each pixel. so, it can apply the digital filter on multiple pixels at same time [11].

The third benefit of the RED algorithm is consisting from two filters and each one of them is not depends on the other filter in extracting and spotting the iris features. The two filters will generate two different templates and these templates will compare to each other. The pixel in rectangle template that formed from the vertical filter (which will be called template A) will compared to corresponding pixel in rectangle template that formed from iris horizontal filter (that will be called template B). A new template that set for matching will formed based on comparing of two templates A&B. if the value of pixel in template A is larger than template B a once will set in location that corresponding two compared pixels. In contrast, if the value of the Template A is smaller

than the value of pixel in template B, a zero will set in the location of corresponding to two compared pixels [12].

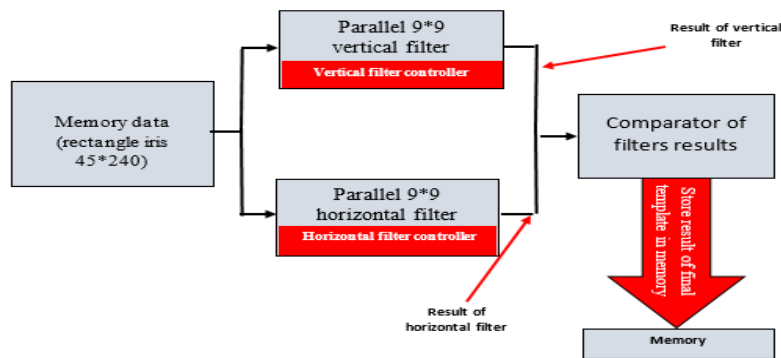

Figure 5. RED filters process in FPGA

### 7. Matching irises

The last operation in the system is the matching process that will be applied depending on Hamming distance and the detections of the identity or verified will be according to threshold and this threshold will decided if the iris template is for the same person or not. The holy process of the Hamming distance is shown in Figure 6.

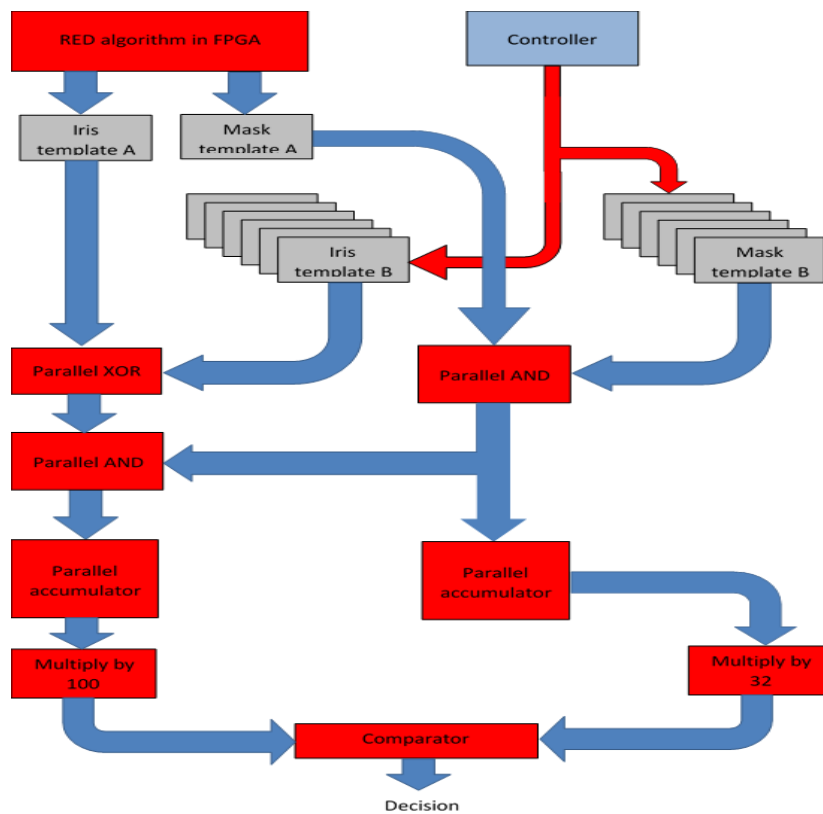

Figure 6. Hamming Distance design in FPGA

### 8. Results and discussion

The results of this paper are checked based on database of CASIA V1 and CASIA Interval and made from these data bases different rectangle iris templates. The results show the different between the iris template due to the variation of iris area that taken since some templates the iris area is contaminated by noise such as eyelash and eyelid. The iris template that chosen shows the diverse of matching results between the different iris template that selected. The best selected iris template is quarter iris due to matching rate is 100% and the size of area is small compare to the second-best selected iris template which is ring iris region. The only issue with this

template is the size is bigger than the quarter iris region so the time needed for verification and identifying is lower than the quarter iris region. The 3rd best selected iris region is lower part iris region. This iris template region is better than full iris region due to that eyelash and eyelid are always interfere within the iris region that selected to be in the full iris template. The results of different iris region are shown in Table 1 and Figure 7.

Table 1. Different iris region template and accuracy rates

Iris template	Size of iris template	Correct Match CASIA V1	Correct Match CASIA Interval
Full iris region	90*480 pixels	89.84%	86%
Lower part iris region	90*240 pixels	99.96%	99.632%
Ring iris region	30*480 pixels	100%	100%
quarter iris region	45*240 pixels	100%	

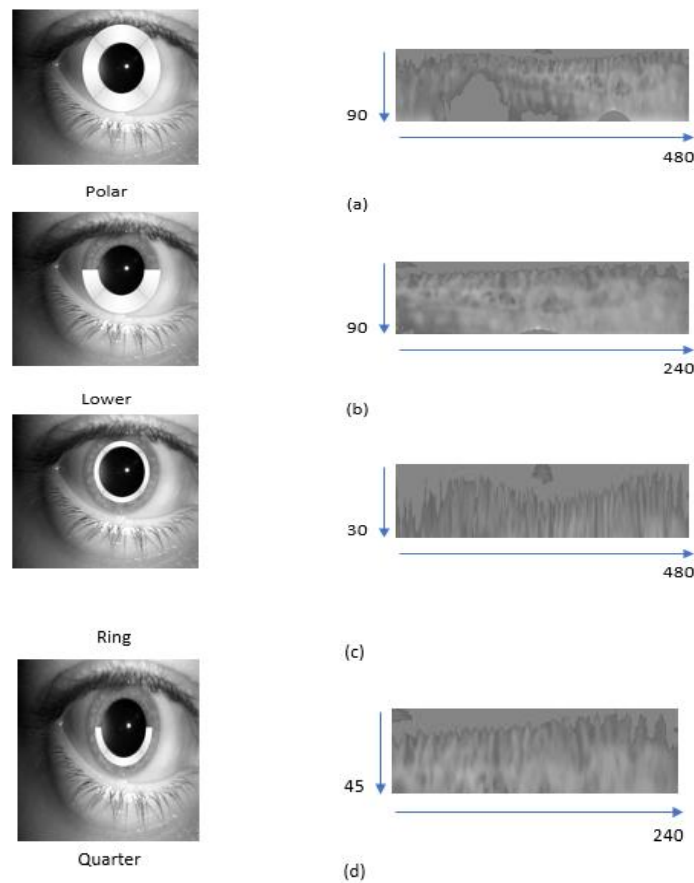

Figure 7. (a) Full iris region, (b) lower part of iris region, (c)ring iris region, (d) Quarter iris region

The different iris region is tested on two different processors. The first processor is used on personal computer (PC) with clock rate 3 GHz and 8 core and 16 threads while the second processor that used is Spartan 7 with clock speed 800MHz. although the speed of clock of PC is faster than spartan 7 but overall system processing in spartan 7 is faster than the PC processor. The problem is due that PC processor is working with a lot of program that used by windows while the system that design in spartan 7 processor is specialized in working of designed iris algorithm to it. Table 2 shows the clock required for performing the designed iris system in both PC processor and FPGA processor and the factor speed of FPGA processor compared to PC processor in each

stages of iris recognition system. While Figure 8 shows the simulation results of implementation of iris recognition system of FPGA processor.

Table 2. Time required to process each stages of iris recognition system in both processor CPU and FPGA and the factor rates of FPGA over CPU

Iris recognition algorithm stages	Time required for performing iris recognition in CPU processor 3 GHz	Time required for performing iris recognition in FPGA processor Spartan 7 800 MHz	Factor FPGA/CPU
Segmentation	4.7939 second	0.1687 Millisecond	28,416.716
Normalization	257.35 millisecond	10.305 Microsecond	24,973.313
RED Algorithm (Digital filter)	47.067 Millisecond	6.517 Microsecond	7,222.1881
Hamming distance	5.661 Millisecond	1.25 NanoSecond	4,528,800,000

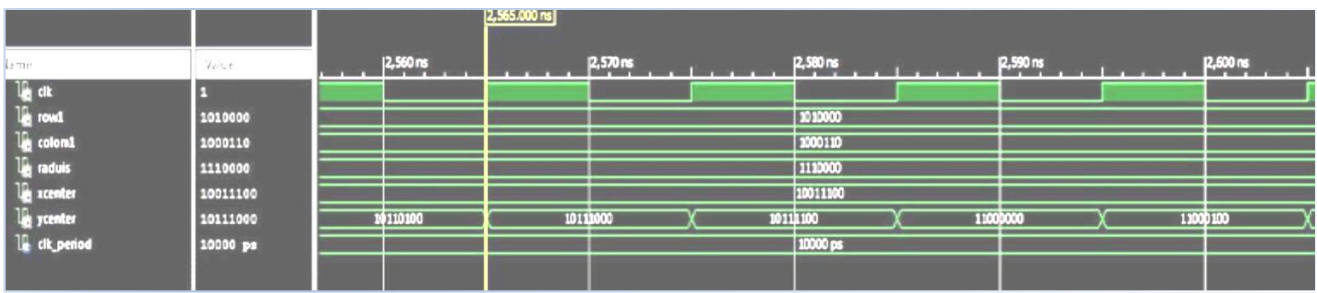

(a)

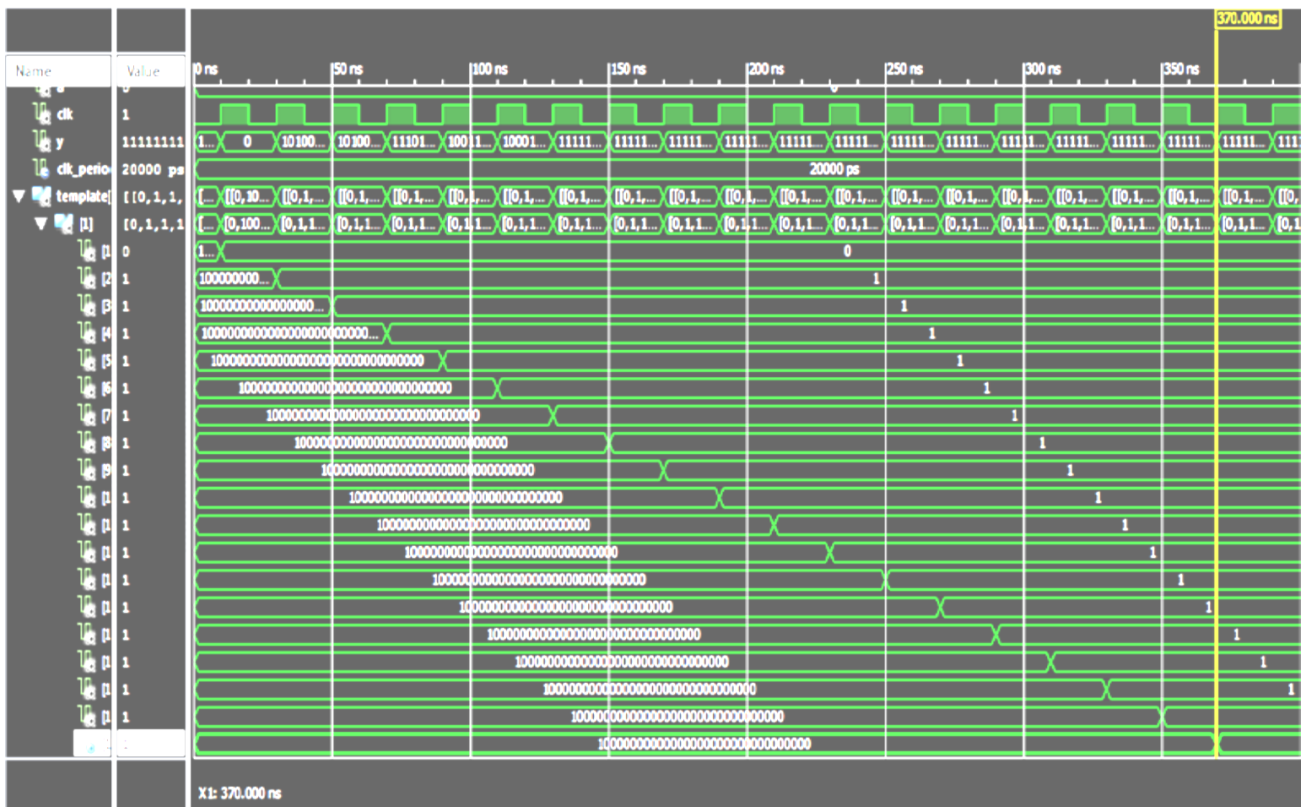

(b)

Figure 8. Simulation results of (a) segmentation and (b) feature extraction in FPGA system

## 9. Conclusion and recommendation

This work introduces major improve in performance and enhancement in the speed process of identification and verification of iris by applied to spartan 7. The processor of Spartan 7 required only 185.523 microsecond. This proposed system is very fast compared to other system of iris recognition system. While the time required for matching is only 1.25 nanosecond. This development of FPGA processor helps in finding criminal or suspected in massive data that located in police stations. The evolution of the system will be applied on the street camera of town to identification of various people and the time required and to applied the system on the mobile due to the evolution of mobile processor and the proposed system that enable this process due to small data resources that required.

## References

- [1] S. Sentanoe, A. S. Nugroho, M. Galinium, R. N. Hartono, M. T. Uliniansyah and M. Layooari, "Iris localization using gradient magnitude and fourier descriptor," in *International Conference on Advanced Computer Science and Information Systems (ICACSIS)*, Jakarta, 2014.
- [2] B. Li, Z. Yan, W. Zuo and F. Yue, "Modeling the individuality of iris pattern and the effectiveness of inconsistent bit masking strategy," in *IEEE International Conference on Identity, Security and Behavior Analysis (ISBA)*, Hong Kong, 2015.
- [3] Bethuna, S. Tadisetty and P. Yadav, "FPGA based Implementation of Iris Recognition," *International Journal of Emerging Technology and Advanced Engineering*, vol. 2, no. 12, pp. 614-618, 2012.
- [4] S. S. Omran and A. A. Al-Hilali, "Quarter of Iris Region Recognition Using the RED Algorithm," in *17th UKSIM-AMSS International Conference on Modelling and Simulation*, cambridge, 2015.
- [5] "Biometrics Ideal Test," CASIA V1, [Online]. Available: <http://biometrics.idealtest.org/downloadDB.do?id=1>. [Accessed 11 9 2015].
- [6] "Biometrics Ideal Test," CASIA Interval, [Online]. Available: <http://biometrics.idealtest.org/downloadDB.do?id=4&subset=1>. [Accessed 11 9 2015].
- [7] H. G. H. a. K. R. P. M. B. Lee, "Noisy ocular recognition based on three convolutional neural networks," *Sensors*, vol. 17, no. 12, p. 2933, 2017.
- [8] W. Z. W. L. Z. a. Z. J. Yuan, "Extraction of Yardang Characteristics Using Object-Based Image Analysis and Canny Edge Detection Methods," *Remote Sensing*, vol. 12, no. 14, 2020.
- [9] T. T. T. a. Y. Alang, "Implementation of circular Hough transform on MRI images for eye globe volume estimation," *International Journal of Biomedical Engineering and Technology*, vol. 32, no. 2, pp. 123-133, 2020.
- [10] R. W. Ives, R. P. Broussard, R. N. Rakvic and S. B. Link, "Iris Recognition," in *Biometrics: From Fiction to Practice*, Pan Stanford, 2013, pp. 65-86.
- [11] R. N. Rakvic, B. J. Ulis, R. P. Broussard, R. W. Ives and N. Steiner, "Parallelizing Iris Recognition," *IEEE Transactions on Information Forensics and Security*, vol. 4, no. 4, pp. 812 - 823, 2009.
- [12] R. N. Rakvic, B. J. Ulis, R. P. Broussard and R. W. Ives, "Iris Template Generation with Parallel Logic," in *42nd Asilomar Conference on Signals, Systems and Computers*, Pacific Grove, CA, 2008.